

الکتروپمپ های سانتریفیوژ (کوپل با فلنج)

Electro Pump

R.P N.F

R.P N.F 4

صنایع الکتروپمپ رایان
Rayan
Electro-Pump Ind. Co.

Centrifuge Pumps (Flanges Couple)



پمپ های گریز از مرکز: NF - NF4

عدد 4 به معنای استفاده از موتور 4 قطبی یا 1450 دور میباشد لذا هر جا NF4 مشاهده گردید به معنای پمپ با دور 1450 میباشد.

- این پمپ ها از لحاظ ساختار پمپ نرمال (N) بوده و به آنها حلزونی نیز گفته می شود.
- پمپ های یک طبقه که از قسمت انتها مکش دارند.
- یاتاقان های پمپ متشکل از دو بلبرینگ می باشد.
- مسیر رانش و مکش در یک راستا بوده و نسبت به هم زاویه ۹۰ درجه دارند.

- پمپ به سیل مکانیکی مجهز میباشد.
- شافت پمپ از استنلس استیل میباشد.
- اتصال الکتروموتور و پمپ به یکدیگر با فلنج میباشد. (اتصال با فلنج باعث عدم لرزش بوده و نیازی به شاسی و کوبلینگ نمیباشد.)
- الکتروموتور القایی دو یا چهار قطبی میباشد.
- فرکانس 50HZ, کلاس عایقی F, درجه حفاظت IP 54.

شرایط استفاده:

- درجه حرارت سیال از ۱۰- تا ۹۰+ درجه سانتی گراد.
- در صورت استفاده از مکانیکال سیل خاص درجه حرارت سیال از ۱۰- تا ۱۴۰+ درجه سانتی گراد.
- دمای محیط تا ۴۰ درجه سانتی گراد.
- حداکثر فشار کاری تا ۱۰ بار.

موارد کاربرد:

- محصولات عمومی برای پمپاژ مایعات تمیز؛ بدون مواد ساینده؛ غیرقابل انفجار و سیالانی که برای قطعات چدنی پمپ مضر نباشد، مناسب است.
- برای آب آشامیدنی.
- برای سیستم های گرمایش و سرمایش و سیرکولاسیون.
- برای پمپاژ پسماند.
- برای بوسترپمپ آتششانی.
- برای آبیاری و سیستم های آبیاری تحت فشار.

نحوه نام گذاری:

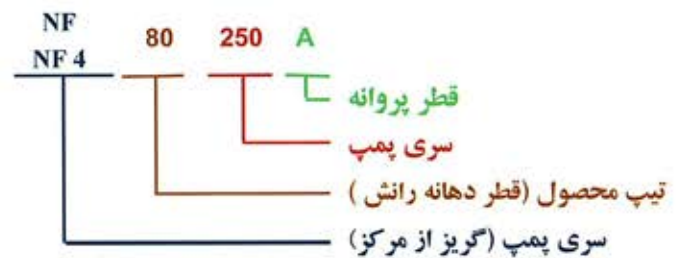

گردش پمپ:

گردش پمپ در صورت مشاهده از طرف دهانه مکش بر خلاف گردش عقربه های ساعت میباشد.



جدول جنس قطعات پمپ NF , NF4

جنس قطعه بر اساس سیال مورد پمپاژ				نام قطعه	کد قطعه	ردیف
آب دارای املاح مضر؛ نمک یا آب دریا		آبهای معمولی				
استنلس استیل	AISI 316	چدن	Cast Iron GG-20	محفظه رانش و مکش	601	1
استنلس استیل	AISI 316	چدن	Cast Iron GG-20	رینگ محفظه رانش و مکش	613	2
استنلس استیل	AISI 316	چدن	Cast Iron GG-20	پروانه	614	3
استنلس استیل	AISI 316	چدن	Cast Iron GG-20	رینگ سرپوش محفظه یاناقان	613	4
کاغذ	Paper Ring	کاغذ	Paper Ring	واشر کاغذی	733	5
استنلس استیل	AISI 316	چدن	Cast Iron GG-20	سرپوش محفظه یاناقان	694	6
فولاد گالوانیزه	Galvanized	فولاد گالوانیزه	Galvanized	پیچ دوسر دنده	725	7
استنلس استیل	AISI 316	فولاد گالوانیزه	Galvanized	درپوش	766	8
استنلس استیل	AISI 316	فولاد گالوانیزه	Galvanized	مهره سر شافت	729	9
استنلس استیل	AISI 316	فولاد گالوانیزه	Galvanized	واشر تخت	730	10
استنلس استیل	AISI 316	فولاد گالوانیزه	Galvanized	واشر فتری	733	11
Silicon-Silicon-Viton		Silicon-Silicon-Viton		سیل مکانیکی	708	12
استنلس استیل	AISI 316	استنلس استیل	AISI 420	واشر زیر سیل مکانیکی	681	13
استنلس استیل	AISI 316	فسفر برنز	G-CuZn25Al5	مقر سیل مکانیکی	634	14
NBR		NBR		کاسه نمد	735	15
C60/C70		C60/C70		خار فتری	736	16
فولاد	CK45	فولاد	CK45	بوش چاکنت	633	17
فولاد گالوانیزه	Galvanized	فولاد گالوانیزه	Galvanized	پیچ الن	727	18
فولاد گالوانیزه	Galvanized	فولاد گالوانیزه	Galvanized	مهره	729	19
چدن	Cast Iron GG-20	چدن	Cast Iron GG-20	رابط	625	20
چدن	Cast Iron GG-20	چدن	Cast Iron GG-20	فلنج	552	21
فولاد گالوانیزه	Galvanized	فولاد گالوانیزه	Galvanized	پیچ مغزی الن	727	22
استنلس استیل	AISI 316	فولاد گالوانیزه	Galvanized	پیچ	726	23
استنلس استیل	AISI 304	استنلس استیل	AISI 304	توری	749	24
استاندارد	Standard	استاندارد	Standard	بلبرینگ	538	25
فولاد	C 15E	فولاد	C 15E	پیچ قلاب	705	26
استنلس استیل	AISI 316	استنلس استیل	AISI 420	شافت	617	27
استنلس استیل	AISI 316	فولاد	CK - 45	خار پروانه	720	28

محصولات ویژه:

- قطعات پمپ های NF ، NF4 می توانند از آلیاژهای استنلس استیل؛ برنز؛ داپلکس یا چدن داکتیل تولید شوند.
- این محصولات ویژه برای پمپاژ آب دریا، آبهای دارای نمک یا املاح مضر برای چدن معمولی مورد استفاده قرار میگیرند

نقشه انفجاری پمپ NF , NF4

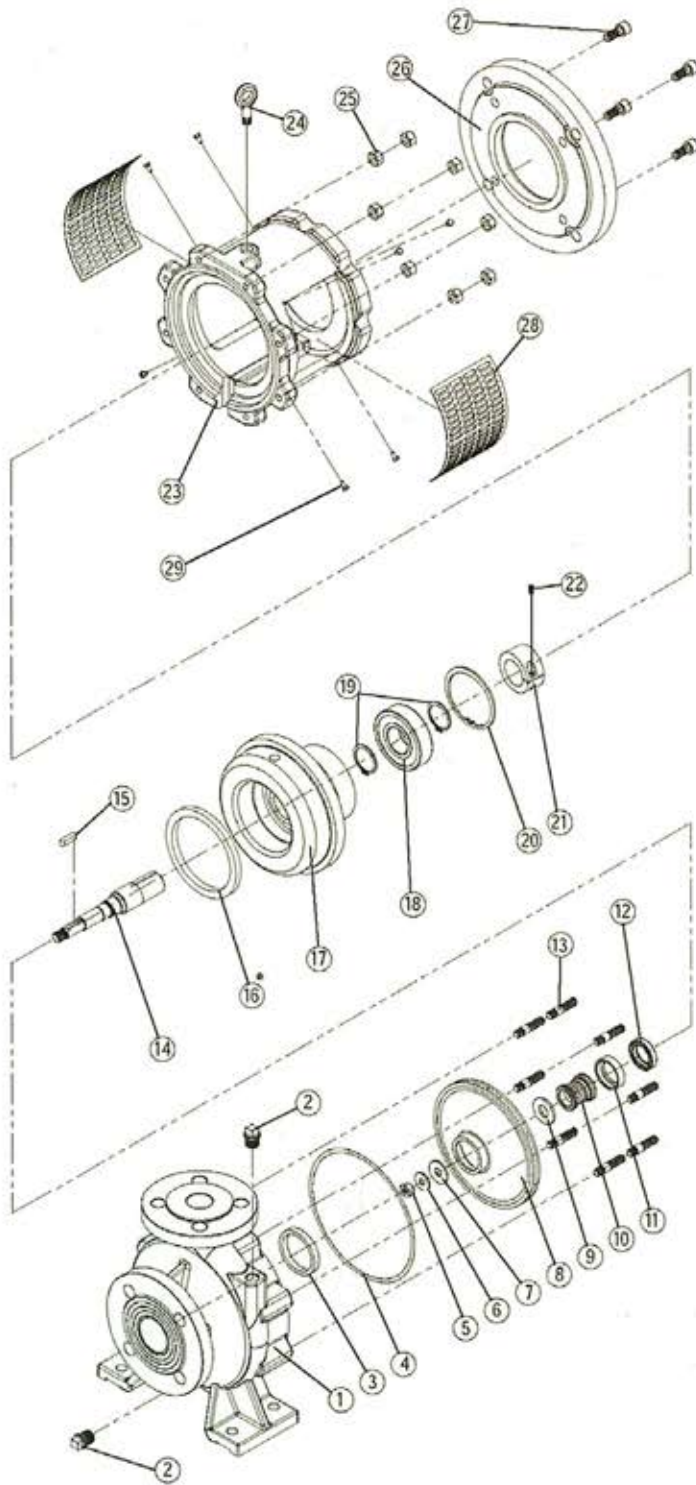

نام و مشخصات قطعات پمپ

نام قطعه	شماره در نقشه	کد قطعه
محفظه رانش و مکش	1	601
درپوش	2	766
رینگ محفظه رانش و مکش	3	613
واشر کاغذی	4	733
مهره سر شافت	5	729
واشر فنری	6	733
واشر تخت	7	730
پروانه	8	614
واشر زیر سیل مکانیکی	9	681
سیل مکانیکی	10	708
مقر سیل مکانیکی	11	634
کاسه نمد	12	735
پیچ دوسر دنده	13	725
شافت	14	617
خار پروانه	15	720
رینگ سربوش محفظه یاناقان	16*	613
سربوش محفظه یاناقان	17	694
بلبرینگ	18	538
خار فنری	19	736
خار فنری	20	736
بوش چاکنت	21	633
پیچ زن	22	727
رابط	23	625
پیچ فلانج	24	705
مهره	25	729
فلنج	26	552
پیچ مغزی زن	27	727
نوری	28	749
پیچ	29	726

جدول افت ناشی از اصطکاک در لوله فولادی (بر حسب متر)

قطر لوله	Q m ³ /h	1	3	6	9	12	18	24	30	36	42	48	60	90	120	180	240	300	360	420			
G mm	Q l/s	0,3	0,8	1,7	2,5	3,3	5	6,7	8,3	10	11,7	13,3	16,6	25	33,4	50	66,7	83,4	100	117			
G1 DN 25	$\frac{HL}{V}$	2,7 0,6	21 1,7																				
G 1¼ DN 32		0,7 0,35	5,5 1	22 2,1																			
G 1½ DN 40			1,8 0,7	7 1,35	14 1,9	23 3,2																	
G 2 DN 50			0,5 0,4	2,2 0,8	4 1,25	8 1,5	17 2,5	28 3,2															
G 2½ DN 65				0,6 0,5	1,2 0,75	2,1 1	4,2 1,4	8 2	12 2,5	17 3	22 3,4	28 4											
DN 80						0,8 0,7	1,6 0,95	2,8 1,25	4,2 1,6	6,5 2	7,5 2,1	10,5 2,6	15 3,3										
DN 100		$\frac{m/100m}{m/s}$					0,55 0,6	0,9 0,8	1,4 1,1	2 1,25	2,4 1,4	3,5 1,6	5 2	11 3,2	20 4								
DN 125											0,9 0,95	1,2 1,1	1,8 1,4	4 2	6,5 2,7	15 4							
DN 150														0,6 0,9	1,5 1,4	2,5 1,7	5 2,7	8 3,5	14 4,8				
DN 200															0,4 0,8	0,6 1	1,3 1,6	2 2	3,5 2,6	4,6 3	6,5 3,5		
DN 250															0,4 1	0,7 1,3	1,1 1,6	1,6 2	1,6 2	2 2,3			
DN 300																	0,3 0,9	0,45 1,25	0,7 1,4	0,9 1,6			

Q : آبدمی HL : افت هد بر حسب متر به ازای ۱۰۰ متر لوله

V : سرعت انتقال آب

سرعت انتقال آب بر مکش حداکثر 1.5 m/s و برای رانش حداکثر 3 m/s می باشد.

◀ برای محاسبه افت هد در لوله کشی متراژ لوله را بر عدد ۱۰۰ تقسیم کرده و نتیجه را در اعداد آبی رنگ جدول فوق ضرب نمایید.

NF 4 1450 rpm

نوب پمپ	قدرت		جریان A	قطر پروانه D (mm)	قطر فلانچ پمپ (mm)		اندھی (m ³ /h)	4	5	6	7	8	9	10	11	12	12.5	13	14	15	16	
	KW	HP			راشش	مکش																
NF4 32-160 E	0.25	0.34	0.78	130	32	50	H (m)	5.6	5.3	5	4.6	4.1	3.5	2.6	*	*	*	*	*	*	*	*
NF4 32-160 D	0.37	0.5	1	140	32	50		6.6	6.4	6.1	5.8	5.4	4.9	4.3	3.7	3	*	*	*	*	*	*
NF4 32-160 C	0.55	0.75	1.5	150	32	50		7.8	7.6	7.4	7.1	6.8	6.4	5.9	5.4	4.8	4.5	4.1	3.3	*	*	*
NF4 32-160 B	0.55	0.75	1.5	160	32	50		8.8	8.7	8.5	8.3	8	7.7	7.3	6.8	6.3	6	5.8	5.2	4.5	3.8	
NF4 32-160 A	0.75	1	2	169	32	50		10	9.8	9.7	9.4	9.2	8.9	8.6	8.2	7.8	7.5	7.3	6.8	6.2	5.5	

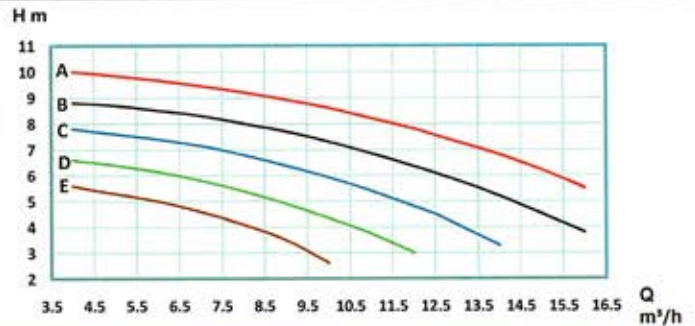
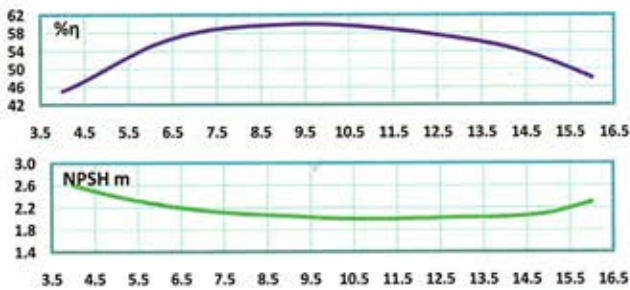

نوب پمپ	قدرت		جریان A	قطر پروانه D (mm)	قطر فلانچ پمپ (mm)		اندھی (m ³ /h)	4	4.5	5	5.5	6	6.5	7	7.5	8	8.5	9	9.5	10	11	
	KW	HP			راشش	مکش																
NF4 32-200 E	0.37	0.5	1	170	32	50	H (m)	9.2	9	8.6	8	*	*	*	*	*	*	*	*	*	*	*
NF4 32-200 D	0.55	0.75	1.5	180	32	50		10.6	10.3	10	9.6	9	*	*	*	*	*	*	*	*	*	*
NF4 32-200 C	0.55	0.75	1.5	190	32	50		12	11.8	11.6	11.3	10.9	10.4	9.8	*	*	*	*	*	*	*	*
NF4 32-200 B	0.75	1	2	200	32	50		13.4	13.3	13.1	12.9	12.6	12.3	11.8	11.2	10.4	*	*	*	*	*	*
NF4 32-200 A	0.75	1	2	209	32	50		14.7	14.6	14.4	14.2	13.9	13.6	13.2	12.6	12	*	*	*	*	*	*

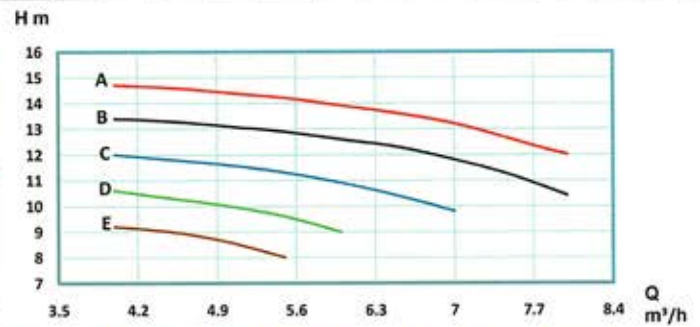
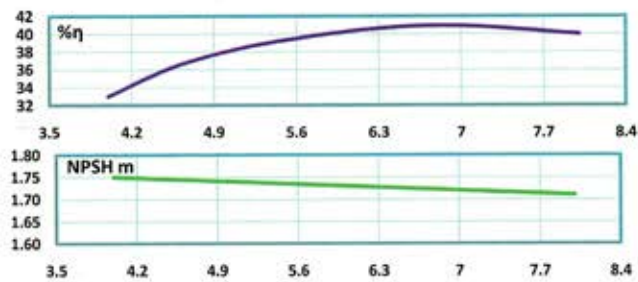

نوب پمپ	قدرت		جریان A	قطر پروانه D (mm)	قطر فلانچ پمپ (mm)		اندھی (m ³ /h)	6	6.5	7	7.5	8	8.5	9	9.5	10	10.5	11	11.5	12	13
	KW	HP			راشش	مکش															
NF4 32-250 F	0.75	1	2	210	32	50	H (m)	12.8	11.9	10.5	*	*	*	*	*	*	*	*	*	*	*
NF4 32-250 E	1.1	1.5	3	220	32	50		14.5	14.2	13.4	12	*	*	*	*	*	*	*	*	*	*
NF4 32-250 D	1.5	2	4	230	32	50		16.3	16	15.5	14.8	14	*	*	*	*	*	*	*	*	*
NF4 32-250 C	1.5	2	4	240	32	50		18	17.8	17.5	17	16.3	15.5	14.5	*	*	*	*	*	*	*
NF4 32-250 B	1.5	2	4	250	32	50		20	19.8	19.5	19.1	18.5	17.8	17	16	15	*	*	*	*	*
NF4 32-250 A	2.2	3	5	259	32	50		21.5	21.4	21.2	20.9	20.6	20.1	19.5	18.7	17.6	16	14	*	*	*

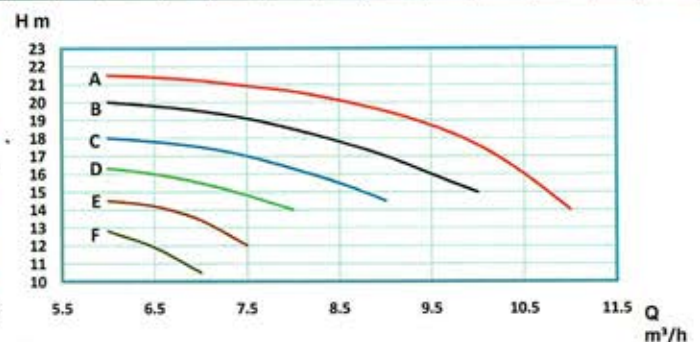
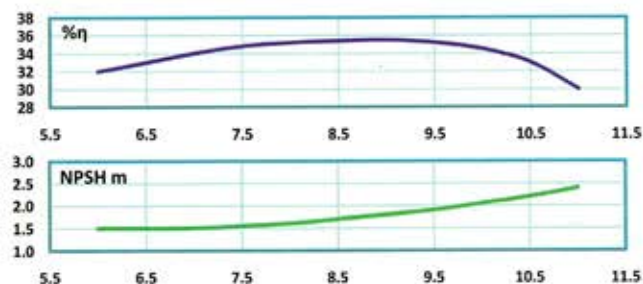

NF 4 1450 rpm

نیم پمپ	قدرت		جریان A	قطر پروانه D (mm)	قطر فلانچ پمپ (mm)		آبدهی (m ³ /h)	6	8	10	11	12	14	15	16	17	18	20	22	25	30
	KW	HP			رانس	مکش		H (m)													
NF4 40-125 G	0.25	0.3	0.78	110	40	65	H (m)	3.5	3.3	3	2.8	2.6	2.1	1.8	1.5	1.2	*	*	*	*	*
NF4 40-125 F	0.25	0.3	0.78	115	40	65		4	3.8	3.5	3.3	3.1	2.6	2.3	2	1.6	*	*	*	*	*
NF4 40-125 E	0.25	0.3	0.78	120	40	65		4.4	4.2	3.9	3.7	3.5	3	2.7	2.4	2	1.6	*	*	*	*
NF4 40-125 D	0.37	0.5	1	125	40	65		4.9	4.7	4.4	4.2	4	3.6	3.3	3	2.7	2.3	*	*	*	*
NF4 40-125 C	0.37	0.5	1	130	40	65		5.3	5.2	4.9	4.7	4.5	4.1	3.8	3.5	3.2	2.8	*	*	*	*
NF4 40-125 B	0.37	0.5	1	135	40	65		5.6	5.7	5.4	5.3	5.1	4.7	4.5	4.2	3.9	3.5	2.7	*	*	*
NF4 40-125 A	0.37	0.5	1	139	40	65		6.2	6.1	5.9	5.7	5.5	5.1	5.9	4.6	4.3	3.9	3.2	*	*	*

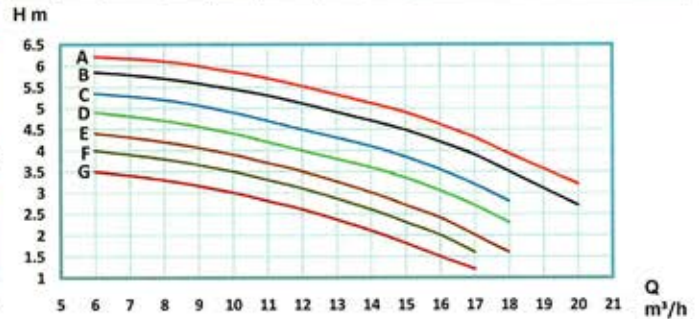
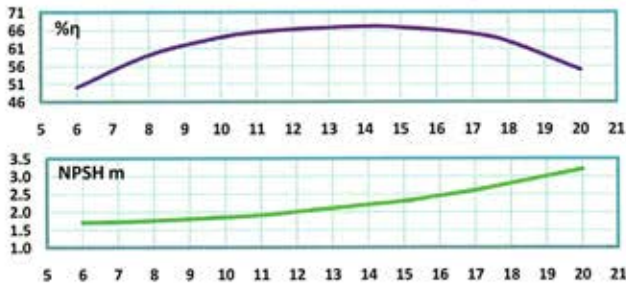

نیم پمپ	قدرت		جریان A	قطر پروانه D (mm)	قطر فلانچ پمپ (mm)		آبدهی (m ³ /h)	6	7	8	9	10	11	12	13	14	15	16	17	18	20
	KW	HP			رانس	مکش		H (m)													
NF4 40-160 E	0.25	0.3	0.78	130	40	65	H (m)	5.6	5.4	5.2	4.9	4.5	4	*	*	*	*	*	*	*	*
NF4 40-160 D	0.37	0.5	1	140	40	65		6.7	6.6	6.4	6.2	5.9	5.6	5.2	4.7	4	*	*	*	*	*
NF4 40-160 C	0.55	0.75	1	150	40	65		7.7	7.6	7.5	7.4	7.2	6.9	6.6	6.2	5.7	5.2	*	*	*	*
NF4 40-160 B	0.75	1	2	160	40	65		8.8	8.7	8.6	8.5	8.4	8.2	8	7.7	7.4	7	6.5	5.8	*	*
NF4 40-160 A	0.75	1	2	169	40	65		9.9	9.8	9.7	9.6	9.5	9.4	9.2	9	8.8	8.5	8.2	7.7	7.2	5.8

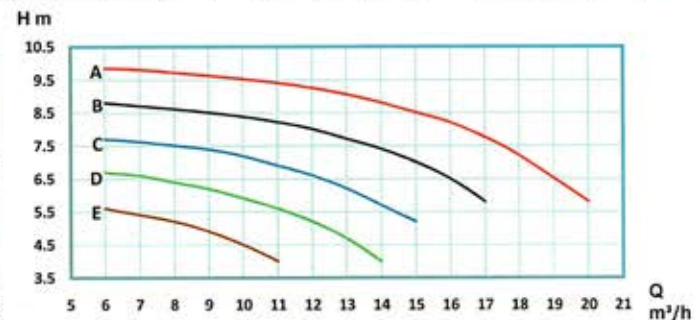
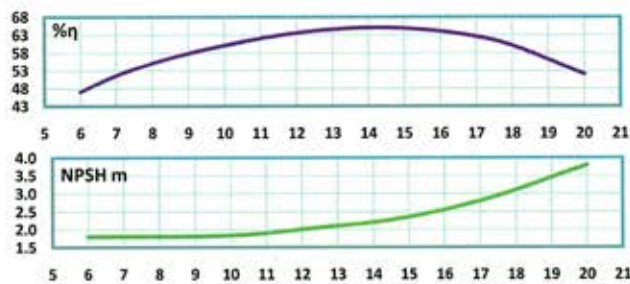

نیم پمپ	قدرت		جریان A	قطر پروانه D (mm)	قطر فلانچ پمپ (mm)		آبدهی (m ³ /h)	6	7	8	9	10	11	12	13	14	15	16	17	18	19
	KW	HP			رانس	مکش		H (m)													
NF4 40-200 E	0.55	0.75	1	170	40	65	H (m)	9.3	9.1	8.8	8.4	7.9	7.2	6.2	*	*	*	*	*	*	*
NF4 40-200 D	0.75	1	1	180	40	65		10.6	10.4	10.2	9.9	9.5	8.9	8.2	7.4	6.6	*	*	*	*	*
NF4 40-200 C	1.1	1.5	3	190	40	65		12	11.8	11.6	11.3	11	10.6	10.1	9.4	8.7	*	*	*	*	*
NF4 40-200 B	1.1	1.5	3	200	40	65		13.3	13.2	13	12.8	12.6	12.3	11.9	11.4	10.8	10.2	9.4	8.4	*	*
NF4 40-200 A	1.5	2	4	209	40	65		14.6	14.5	14.4	14.2	14	13.8	13.5	13.1	12.7	12.2	11.5	10.8	9.8	8.8

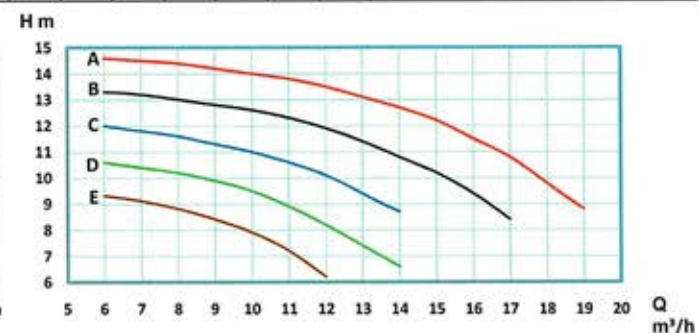
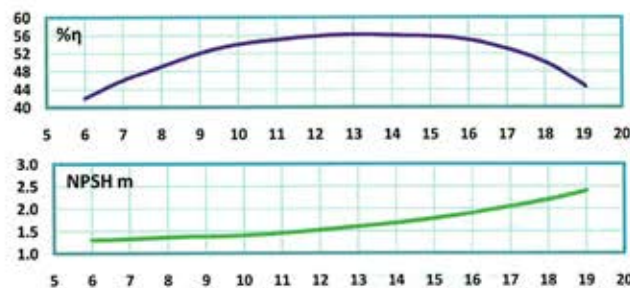

NF 4 1450 rpm

نوب پمپ	قدرت		جریان A	قطر بروانه D (mm)	قطر فلایج پمپ (mm)		آبدهی (m ³ /h)	15	16	17	18	19	20	21	22	24	25	26	27	28	30	
	KW	HP			رانس	مکس																
NF4 40-250 F	1.1	1.5	3	210	40	65	H (m)	13	12.8	12.5	12.1	11.6	10.9	10.1	9.2	*	*	*	*	*	*	*
NF4 40-250 E	1.5	2	4	220	40	65		14.7	14.5	14.2	13.9	13.6	13.1	12.6	12	10.5	9.5	*	*	*	*	*
NF4 40-250 D	2.2	3	5	230	40	65		16.4	16.2	16	15.7	15.3	14.9	14.5	14	12.8	12.1	11.4	10.5	*	*	
NF4 40-250 C	3	4	7	240	40	65		18.9	18.7	18.4	18	17.6	17.2	16.7	16.2	15.1	14.5	13.8	13	12	*	
NF4 40-250 B	3	4	7	250	40	65		20.8	20.7	20.5	20.2	19.8	19.4	19	18.6	17.7	17.2	16.6	15.8	15	13.2	
NF4 40-250 A	4	5.5	9	259	40	65		22.8	22.7	22.5	22.2	21.9	21.6	21.3	21	20.1	19.6	19.1	18.4	17.7	16	

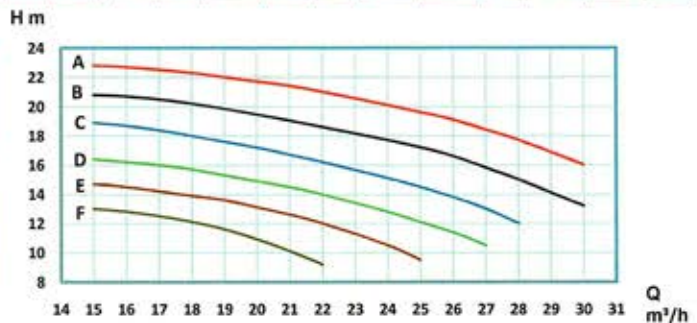
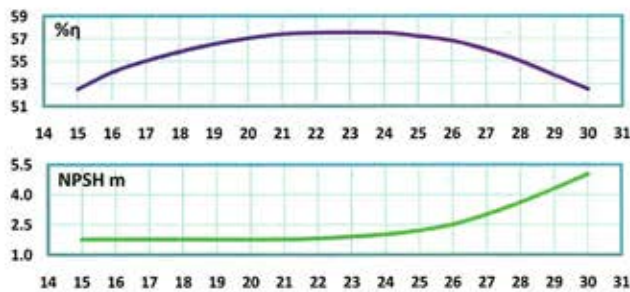

نوب پمپ	قدرت		جریان A	قطر بروانه D (mm)	قطر فلایج پمپ (mm)		آبدهی (m ³ /h)	6	7	8	9	10	11	11	12	13	14	15	15	16	17
	KW	HP			رانس	مکس															
NF4 40-315 F	2.2	3	5	270	40	65	H (m)	24.2	23.9	23.7	23.3	22.6	22.1	21.3	19.1	*	*	*	*	*	*
NF4 40-315 E	2.2	3	5	280	40	65		26.7	26.4	26	25.7	25.2	24.8	24.3	22.9	20.7	18	*	*	*	*
NF4 40-315 D	3	4	7	290	40	65		29	28.7	28.5	28.2	27.8	27.5	27.1	26.1	24.8	22.4	20.7	19	*	*
NF4 40-315 C	4	5.5	9	300	40	65		31	30.9	30.8	30.7	30.4	30.1	29.7	28.8	27.5	25.5	24	22	*	*
NF4 40-315 B	4	5.5	9	310	40	65		34.2	34.1	34	33.9	33.8	33.6	33.4	32.7	31.4	29.3	27.9	26.5	23	*
NF4 40-315 A	4	5.5	9	319	40	65		37.4	37.3	37.2	37	36.7	36.5	36.2	35.5	34.4	33.1	32.1	31	28	24

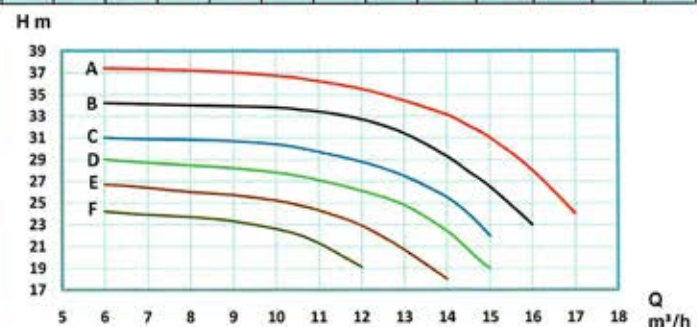
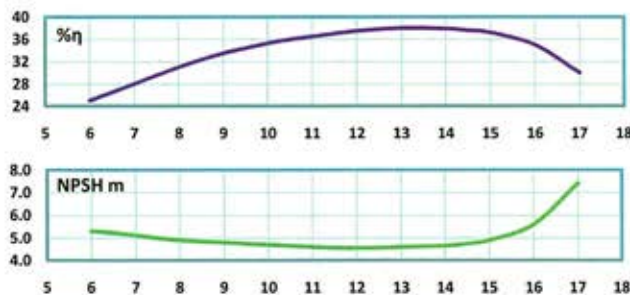

نوب پمپ	قدرت		جریان A	قطر بروانه D (mm)	قطر فلایج پمپ (mm)		آبدهی (m ³ /h)	10	12	15	17.5	20	22.5	25	26	28	30	33	35	37	39
	KW	HP			رانس	مکس															
NF4 50-160 E	0.55	0.75	1	130	50	65	H (m)	5.2	5.1	4.9	4.7	4.4	*	*	*	*	*	*	*	*	*
NF4 50-160 D	0.55	0.75	1	140	50	65		6.2	6.1	5.9	5.7	5.4	5	4.6	4.4	*	*	*	*	*	*
NF4 50-160 C	0.75	1	1	150	50	65		7.2	7.1	6.9	6.7	6.4	6	5.6	5.4	5	4.6	*	*	*	*
NF4 50-160 B	1.1	1.5	3	160	50	65		8.2	8.1	7.9	7.7	7.4	7	6.6	6.4	6	5.6	5	*	*	*
NF4 50-160 A	1.5	2	4	169	50	65		9.2	9.1	8.9	8.7	8.4	8.1	7.6	7.4	7	6.6	6	5.5	5	4.5

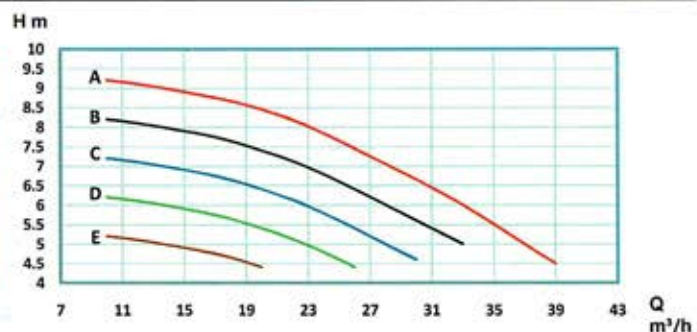
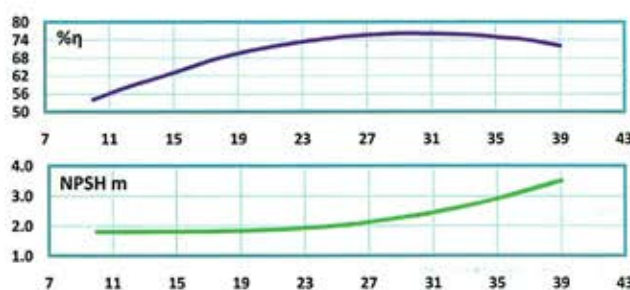

NF 4 1450 rpm

نیم پمپ	قدرت		جریان A	قطر پروانه D (mm)	قطر فلانچ پمپ (mm)		آبدهی (m ³ /h)	15	17.5	20	22.5	25	27.5	30	31	32.5	34	35	37.5	40	41	
	KW	HP			رانس	مکش		H (m)														
NF4 50-200 E	1.1	1.5	3	170	50	65	H (m)	9.2	8.9	8.5	8.1	7.6	*	*	*	*	*	*	*	*	*	*
NF4 50-200 D	1.5	2	4	180	50	65		10.4	10.2	9.9	9.6	9.2	8.7	8.2	8	*	*	*	*	*	*	*
NF4 50-200 C	1.5	2	4	190	50	65		11.8	11.6	11.3	11	10.7	10.4	10	9.8	9.5	9.1	8.8	*	*	*	*
NF4 50-200 B	2.2	3	5	200	50	65		13.2	13	12.8	12.5	12.2	11.9	11.6	11.4	11.1	10.8	10.6	9.9	9.2	*	*
NF4 50-200 A	2.2	3	5	209	50	65		14.5	14.3	14.1	13.9	13.7	13.4	13.1	13	12.8	12.5	12.4	11.9	11.2	10.8	*

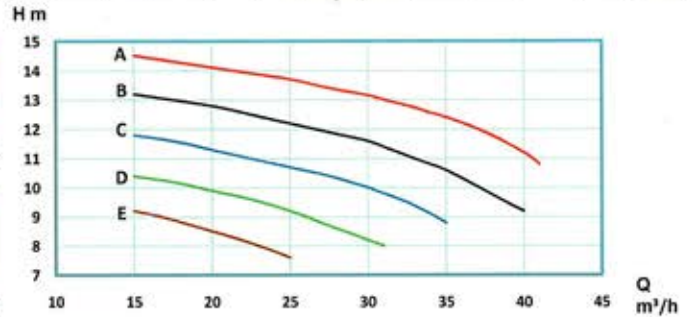
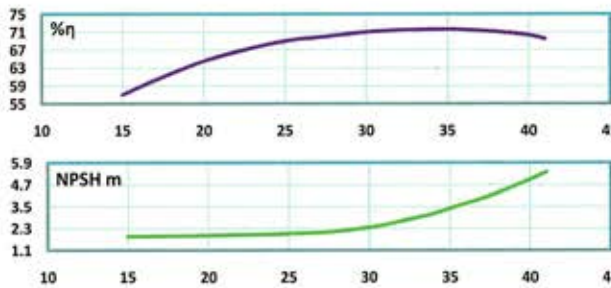

نیم پمپ	قدرت		جریان A	قطر پروانه D (mm)	قطر فلانچ پمپ (mm)		آبدهی (m ³ /h)	15	18	20	23	25	28	30	31	33	34	35	38	40	45
	KW	HP			رانس	مکش		H (m)													
NF4 50-250 E	2.2	3	5	220	50	65	H (m)	15	14.6	14.2	13.6	13	12.1	11.2	10.6	10	9.5	8.7	*	*	*
NF4 50-250 D	2.2	3	5	230	50	65		16.7	16.2	15.6	15.1	14.5	13.7	12.8	12.3	11.7	11.3	10.5	9	*	*
NF4 50-250 C	3	4	7	240	50	65		18.4	18	17.5	17	16.5	15.6	14.7	14.2	13.6	13.2	12.5	11.1	9.6	*
NF4 50-250 B	3	4	7	250	50	65		20.2	19.8	19.5	19	18.5	17.8	17	16.5	16	15.5	14.8	13.5	12	*
NF4 50-250 A	4	5.5	9	259	50	65		22	21.7	21.4	20.9	20.4	19.8	19.2	18.8	18.3	17.9	17.3	16.1	14.8	12

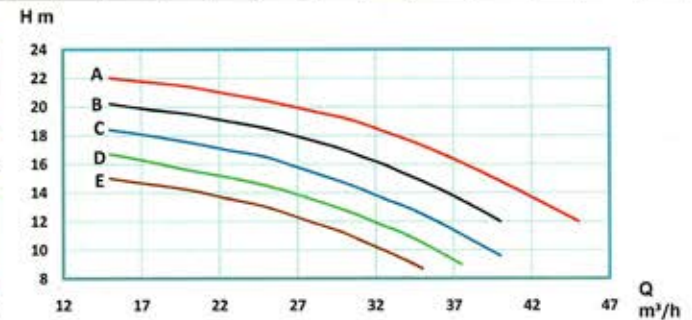
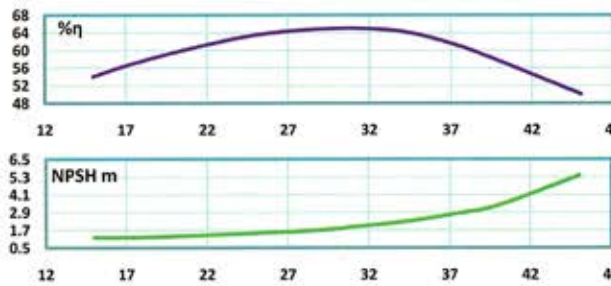

نیم پمپ	قدرت		جریان A	قطر پروانه D (mm)	قطر فلانچ پمپ (mm)		آبدهی (m ³ /h)	15	18	20	23	25	28	30	31	33	34	35	38	40	45
	KW	HP			رانس	مکش		H (m)													
NF4 50-315 F	4	5.5	9	270	50	65	H (m)	23.8	23.4	23	22.5	21.9	21.1	20.2	19.6	19	18.4	17.5	*	*	*
NF4 50-315 E	4	5.5	9	280	50	65		26	25.5	25	24.5	24	23.3	22.4	21.9	21.3	20.8	19.9	18	*	*
NF4 50-315 D	5.5	7.5	12	290	50	65		28	27.5	27	26.6	26.1	25.5	24.8	24.3	23.8	23.3	22.5	21	19.3	*
NF4 50-315 C	7.5	10	16	300	50	65		30.5	30	29.5	29	28.4	27.7	27	26.6	26.1	25.7	25	23.9	22.5	*
NF4 50-315 B	7.5	10	16	310	50	65		33	32.7	32.4	31.9	31.3	30.7	30	29.5	29	28.5	27.9	26.5	25	*
NF4 50-315 A	7.5	10	16	319	50	65		35.5	35.2	34.9	34.5	34	33.4	32.7	32.3	31.8	31.4	30.8	29.4	27.9	23.5

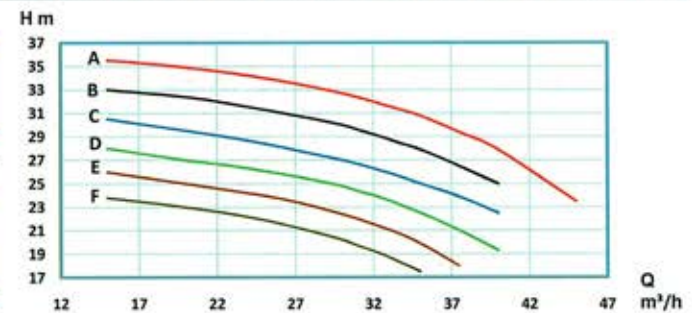
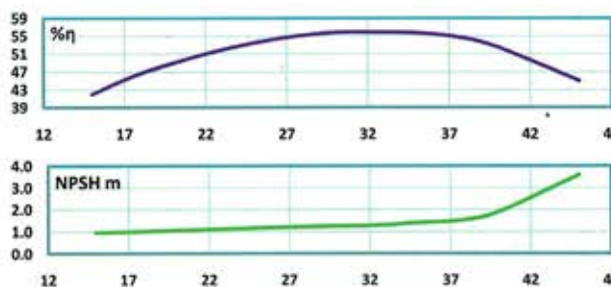

NF 4 1450 rpm

نوب پمپ	قدرت		جریان A	قطر پروانه D (mm)	قطر فلانچ پمپ (mm)		انهدی (m ³ /h)	20	25	30	35	40	45	48	50	55	60	65	70	80	85	
	KW	HP			رانس	مکش																
NF4 65-125 D	0.55	0.75	1	110	65	80	H (m)	3.4	3.2	3	2.7	2.4	2.1	1.9	1.7	*	*	*	*	*	*	*
NF4 65-125 C	0.75	1	1	120	65	80		4.2	4.1	3.9	3.7	3.4	3	2.8	2.6	2.2	1.8	*	*	*	*	*
NF4 65-125 B	1.1	1.5	3	130	65	80		5.2	5	4.8	4.6	4.4	4.1	3.9	3.7	3.3	2.8	2.2	1.6	*	*	
NF4 65-125 A	1.5	2	4	139	65	80		6.2	6.1	6	5.8	5.6	5.4	5.3	5.1	4.9	4.6	4.2	3.8	2.7	2.1	

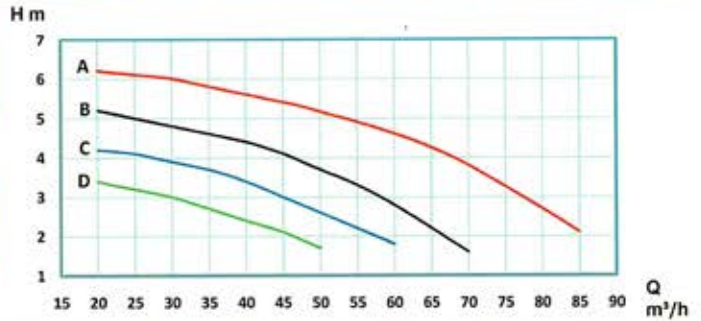
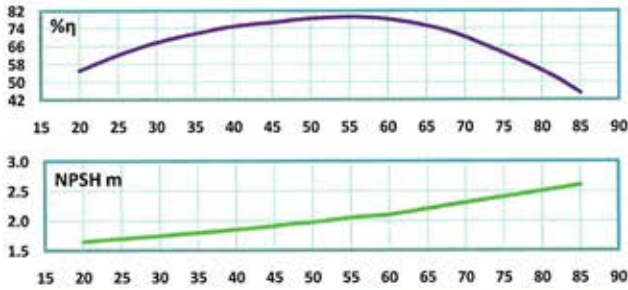

نوب پمپ	قدرت		جریان A	قطر پروانه D (mm)	قطر فلانچ پمپ (mm)		انهدی (m ³ /h)	20	25	30	35	40	45	50	55	60	65	70	75	80	90
	KW	HP			رانس	مکش															
NF4 65-160 E	0.75	1	2	130	65	80	H (m)	5	4.8	4.6	4.3	4	3.6	3	2.3	1.6	*	*	*	*	*
NF4 65-160 D	1.1	1.5	3	140	65	80		6.1	5.9	5.7	5.4	5	4.6	4.1	3.6	3	2.2	*	*	*	*
NF4 65-160 C	1.5	2	4	150	65	80		7.3	7.1	6.9	6.6	6.3	5.9	5.4	4.8	4.2	3.5	2.8	1.9	*	*
NF4 65-160 B	1.5	2	4	160	65	80		8.6	8.4	8.2	7.9	7.6	7.3	6.9	6.3	5.7	5	4.3	3.6	2.9	*
NF4 65-160 A	2.2	3	5	169	65	80		9.6	9.5	9.4	9.2	9	8.7	8.3	7.8	7.3	6.7	6.1	5.4	4.6	2.7

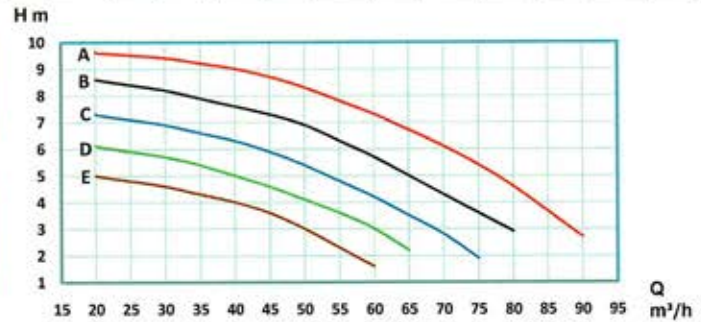
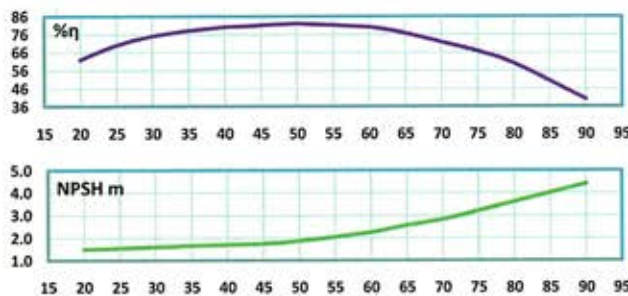

نوب پمپ	قدرت		جریان A	قطر پروانه D (mm)	قطر فلانچ پمپ (mm)		انهدی (m ³ /h)	20	25	30	35	40	45	48	50	55	60	65	70	75	82
	KW	HP			رانس	مکش															
NF4 65-200 E	1.5	2	4	170	65	80	H (m)	9.8	9.6	9.3	8.9	8.3	7.6	7.3	7	6.3	5.6	*	*	*	*
NF4 65-200 D	2.2	3	5	180	65	80		10.9	10.7	10.5	10.1	9.6	9	8.7	8.4	7.8	7.1	6.3	5.4	*	*
NF4 65-200 C	3	4	7	190	65	80		12.4	12.2	12	11.6	11.2	10.7	10.4	10.1	9.4	8.8	7.9	7	*	*
NF4 65-200 B	3	4	7	200	65	80		13.7	13.5	13.3	13	12.6	12.2	12	11.7	11.1	10.5	9.8	9	8	*
NF4 65-200 A	4	5.5	9	209	65	80		14.9	14.7	14.5	14.3	14	13.6	13.4	13.2	12.8	12.3	11.7	11	10.1	8.7

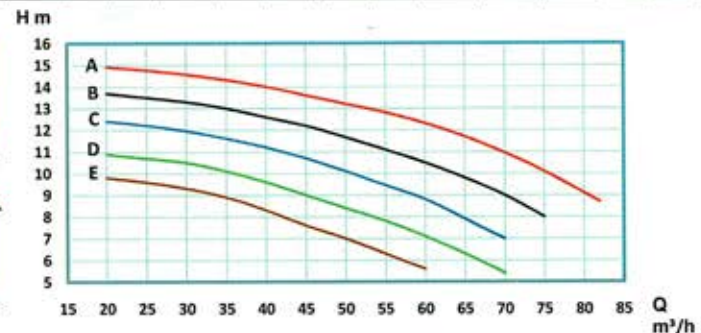
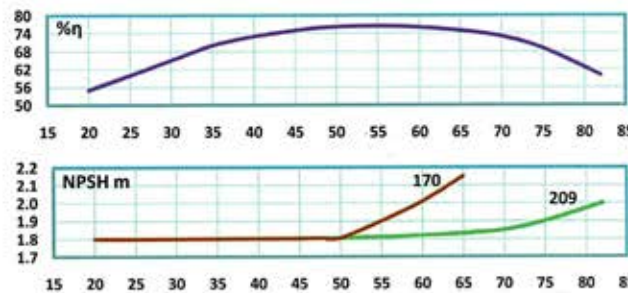

NF 4 1450 rpm

نیم پمپ	قدرت		حریان A	قطر پروانه D (mm)	قطر فلانچ پمپ (mm)		اندهی (m ³ /h)	20	25	30	35	40	45	50	55	60	65	70	75	80	88
	KW	HP			راشش	مکش															
NF4 65-250 F	3	4	7	210	65	80	H (m)	14.9	14.7	14.4	14	13.5	12.8	12.1	11.1	10	8.5	*	*	*	*
NF4 65-250 E	4	5.5	9	220	65	80		16.5	16.3	16	15.6	15.2	14.6	14	13.1	12.1	10.8	9.5	*	*	*
NF4 65-250 D	5.5	7.5	12	230	65	80		18.2	18	17.7	17.3	17	16.5	15.9	15	14	12.7	11.3	9.5	*	*
NF4 65-250 C	5.5	7.5	12	240	65	80		20	19.7	19.4	19.1	18.7	18.3	17.8	17	16	14.8	13.5	11.7	9.7	*
NF4 65-250 B	7.5	10	16	250	65	80		21.8	21.5	21.3	21	20.7	20.3	19.8	19.2	18.4	17.4	16.3	15	13.5	*
NF4 65-250 A	7.5	10	16	259	65	80		24	23.8	23.5	23.1	22.7	22.3	21.8	21.1	20.4	19.4	18.4	17.2	15.6	12.8

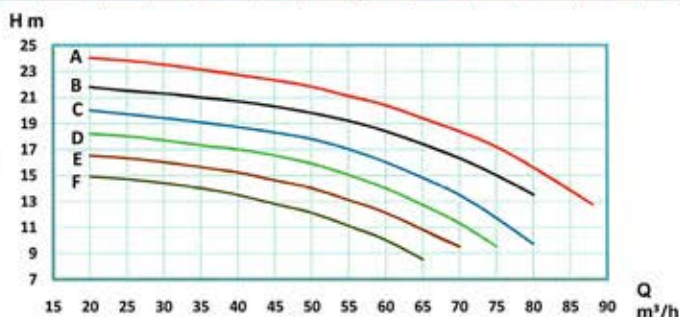
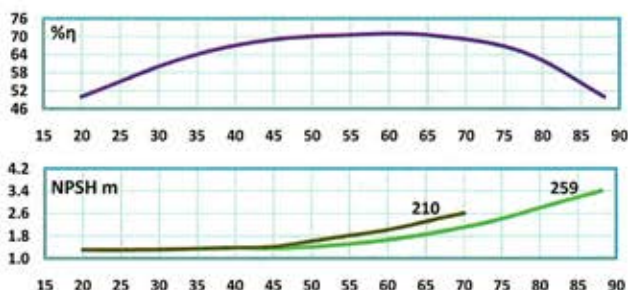

نیم پمپ	قدرت		حریان A	قطر پروانه D (mm)	قطر فلانچ پمپ (mm)		اندهی (m ³ /h)	20	25	30	35	40	45	50	55	60	65	70	75	80	90
	KW	HP			راشش	مکش															
NF4 65-315 F	5.5	7.5	12	270	65	80	H (m)	23.7	23.5	23	22.5	21.9	21	19.9	18.5	17	15.5	*	*	*	*
NF4 65-315 E	7.5	10	16	280	65	80		26	25.9	25.7	25.3	24.7	23.9	22.9	21.6	20.1	18.4	16.5	*	*	*
NF4 65-315 D	11	15	22	290	65	80		27.9	27.8	27.6	27.3	26.9	26.2	25.4	24.2	22.9	21.5	20	18	*	*
NF4 65-315 C	11	15	22	300	65	80		30.2	30	29.8	29.4	29	28.5	27.8	26.7	25.5	24	22.3	20.2	18	*
NF4 65-315 B	11	15	22	310	65	80		32.3	32.1	31.9	31.5	31.1	30.5	29.9	29	27.9	26.5	25	23.2	21	*
NF4 65-315 A	11	15	22	319	65	80		35	34.8	34.5	34.1	33.6	33	32.3	31.5	30.4	29	27.5	25.7	23.9	19.5

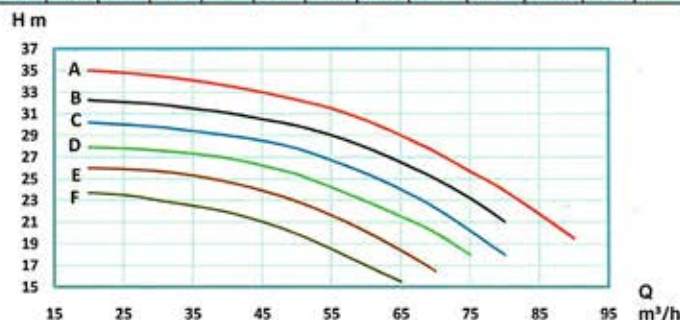
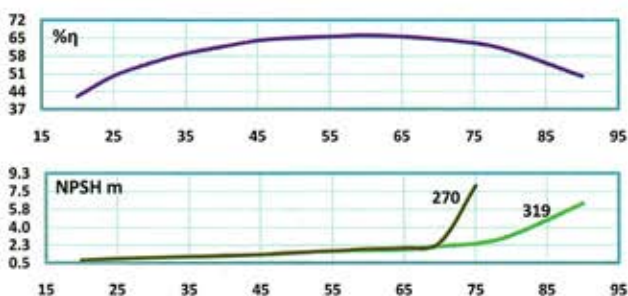

نیم پمپ	قدرت		حریان A	قطر پروانه D (mm)	قطر فلانچ پمپ (mm)		اندهی (m ³ /h)	40	50	60	70	80	90	100	110	115	120	125	130	135	138
	KW	HP			راشش	مکش															
NF4 80-160 E	1.1	1.5	3	130	80	100	H (m)	4.5	4.2	3.9	3.5	3	2.3	1.5	*	*	*	*	*	*	*
NF4 80-160 D	1.1	1.5	3	140	80	100		5.6	5.4	5.1	4.7	4.2	3.6	3	2.2	1.7	*	*	*	*	*
NF4 80-160 C	2.2	3	5	150	80	100		6.8	6.7	6.4	6	5.5	4.9	4.2	3.4	3	2.5	*	*	*	*
NF4 80-160 B	2.2	3	5	160	80	100		8.2	8	7.7	7.4	7	6.5	5.8	5	4.5	4	3.5	2.9	*	*
NF4 80-160 A	3	4	7	169	80	100		9.4	9.3	9.1	8.9	8.6	8.2	7.6	6.9	6.5	6	5.5	4.9	4.2	3.7

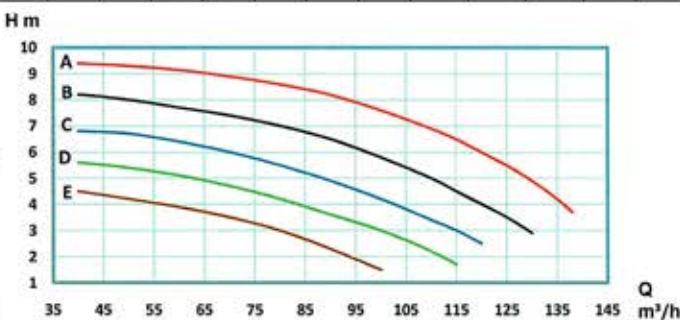
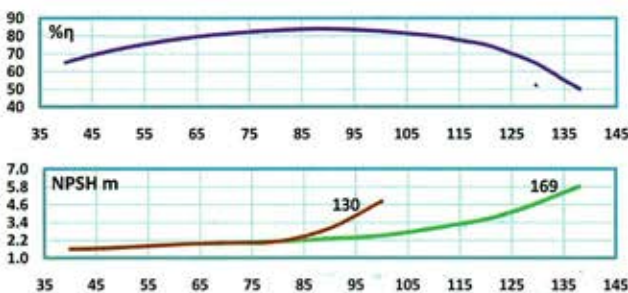

NF 4 1450 rpm

نوب پمپ	قدرت		جریان A	قطر پروانه D (mm)	قطر فلانچ پمپ (mm)		آبدهی (m ³ /h)	40	45	50	55	60	65	70	75	80	90	100	110	120	126
	KW	HP			رایش	مکش		H (m)													
NF4 80-200 E	2.2	3	5	170	80	100	H (m)	8.7	8.5	8.2	7.9	7.6	7.2	6.7	6.2	5.7	4.5	*	*	*	*
NF4 80-200 D	3	4	7	180	80	100		9.9	9.8	9.6	9.4	9.1	8.8	8.4	8	7.5	6.4	4.8	*	*	*
NF4 80-200 C	4	5.5	9	190	80	100		11.3	11.2	11.1	10.9	10.7	10.4	10.1	9.7	9.2	8.1	6.7	5.2	*	*
NF4 80-200 B	4	5.5	9	200	80	100		13	12.9	12.7	12.5	12.3	12	11.6	11.2	10.8	9.8	8.6	7.4	5.9	*
NF4 80-200 A	5.5	7.5	12	209	80	100		14.3	14.2	14.1	13.9	13.7	13.4	13.1	12.8	12.4	11.5	10.5	9.2	7.7	6.8

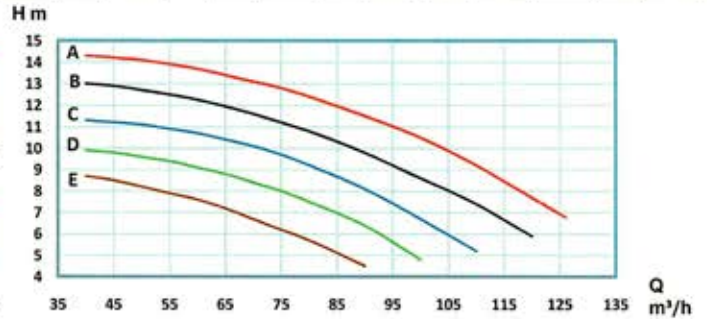
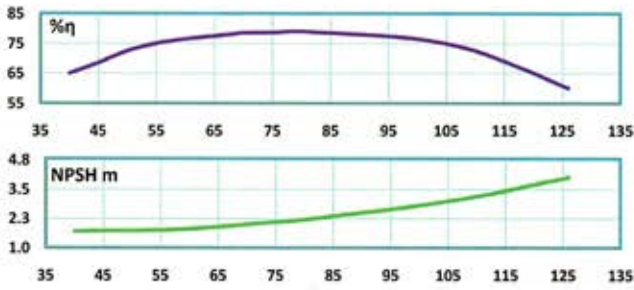

نوب پمپ	قدرت		جریان A	قطر پروانه D (mm)	قطر فلانچ پمپ (mm)		آبدهی (m ³ /h)	40	50	60	70	80	90	100	110	115	120	130	140	145	150
	KW	HP			رایش	مکش		H (m)													
NF4 80-250 F	4	5.5	9	210	80	100	H (m)	14.2	13.8	13.3	12.5	11.4	10	8.5	6.5	*	*	*	*	*	*
NF4 80-250 E	5.5	7.5	12	220	80	100		15.8	15.4	15	14.4	13.5	12.4	10.9	9	8	7	*	*	*	*
NF4 80-250 D	7.5	10	16	230	80	100		17.5	17.2	16.8	16.3	15.5	14.4	12.9	11	10.1	9	*	*	*	*
NF4 80-250 C	7.5	10	16	240	80	100		19.2	19	18.6	18	17.3	16.4	15.2	13.7	12.8	11.9	10	8.1	*	*
NF4 80-250 B	11	15	22	250	80	100		21.3	21	20.7	20.4	19.9	19.1	18	16.5	15.7	14.8	13	11	9.8	*
NF4 80-250 A	11	15	22	259	80	100		22.6	22.5	22.3	21.9	21.4	20.7	19.7	18.5	17.8	17	15.3	13.2	12	10.5

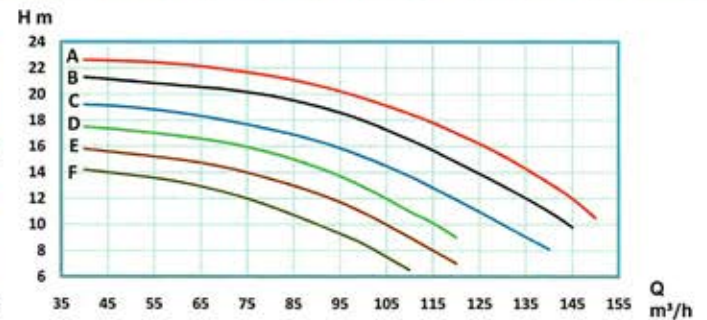
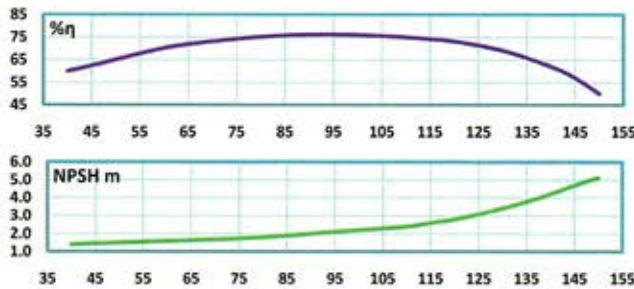

نوب پمپ	قدرت		جریان A	قطر پروانه D (mm)	قطر فلانچ پمپ (mm)		آبدهی (m ³ /h)	40	50	60	70	80	85	90	100	110	120	125	130	140	155
	KW	HP			رایش	مکش		H (m)													
NF4 80-315 F	9.2	12.5	18	270	80	100	H (m)	25	24.4	23.8	22.9	21.8	21.1	20.3	18.2	15.7	13	*	*	*	*
NF4 80-315 E	11	15	22	280	80	100		27	26.5	26	25.1	24	23.3	22.4	20.5	18	15.5	14.2	12.8	*	*
NF4 80-315 D	15	20	29	290	80	100		29	28.7	28.1	27.5	26.6	26	25.3	23.5	21.5	19	17.5	16	*	*
NF4 80-315 C	15	20	29	300	80	100		31.5	31	30.5	29.9	29.1	28.6	28	26.6	24.8	22.5	21.2	19.9	17	*
NF4 80-315 B	15	20	29	310	80	100		34	33.7	33.2	32.7	32	31.5	30.9	29.5	28.1	26.3	25.3	24	21	*
NF4 80-315 A	18.5	25	38	319	80	100		36.3	36	35.5	35	34.3	33.8	33.3	32	30.5	28.7	27.6	26.5	24	19.5

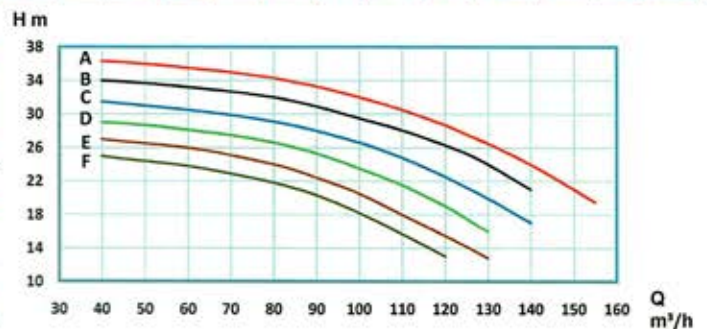
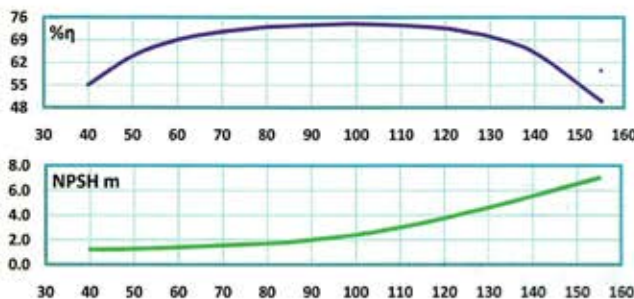

NF 4 1450 rpm

نوب پمپ	قدرت		جریان A	قطر پروانه D (mm)	قطر فلاج پمپ (mm)		آبدهی (m ³ /h)														
	KW	HP			رایش	مکش		40	50	60	65	70	75	80	85	90	95	100	110	120	130
NF4 80-400 E	15	20	29	320	80	100	H (m)	35	33.7	32.5	31.5	30.5	29	27.4	25.5	23.5	20.7	18	*	*	*
NF4 80-400 D	18.5	25	38	340	80	100		40	39	38.2	37.5	36.5	35.2	34	32.5	31	28.9	26.4	20	*	*
NF4 80-400 C	22	30	43.5	360	80	100		45	44.5	44	43.7	43.2	42.5	41.5	40.2	38.7	37	35	29.5	*	*
NF4 80-400 B	30	41	58	380	80	100		50.5	50.2	50	49.5	49.1	48.3	47.5	46.5	45.5	44	42.3	37.8	31	*
NF4 80-400 A	30	41	58	404	80	100		57.5	57.2	57	56.7	56.5	56	55.5	54.7	54	52.9	51.5	47.6	43	37

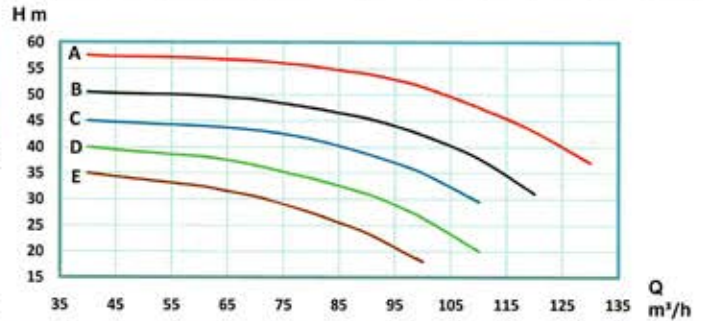
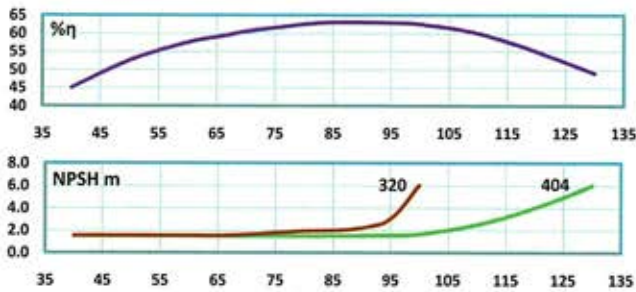

نوب پمپ	قدرت		جریان A	قطر پروانه D (mm)	قطر فلاج پمپ (mm)		آبدهی (m ³ /h)														
	KW	HP			رایش	مکش		40	60	70	80	90	100	120	130	140	150	160	170	180	190
NF4 100-160 E	2.2	3	5	150/110	100	125	H (m)	4.6	4.4	4.3	4.2	4	3.8	3.3	3	2.6	2.2	*	*	*	*
NF4 100-160 D	2.2	3	5	160/120	100	125		5.5	5.3	5.1	5	4.8	4.6	4.2	3.9	3.6	3.2	2.8	2.4	*	*
NF4 100-160 C	3	4	7	169/130	100	125		6.4	6.2	6.1	6	5.8	5.6	5.2	4.9	4.6	4.3	3.9	3.5	*	*
NF4 100-160 B	3	4	7	169/150	100	125		7.4	7.2	7.1	7	6.8	6.6	6.2	5.9	5.6	5.3	4.9	4.5	4	3.5
NF4 100-160 A	4	5.5	9	169	100	125		8.3	8.1	8	7.8	7.7	7.5	7.1	6.8	6.5	6.2	5.8	5.4	4.9	4.4

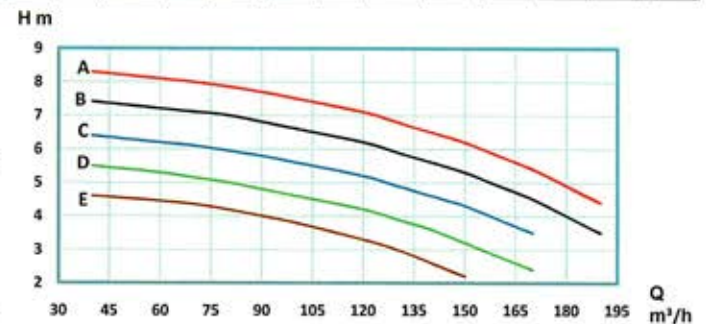
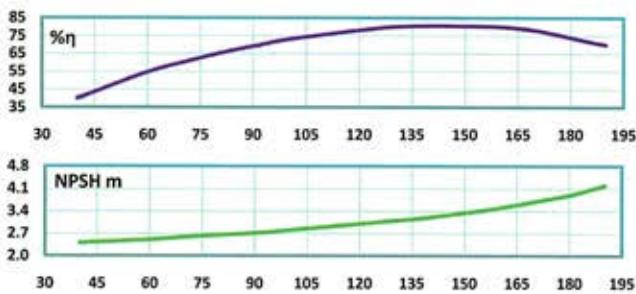

نوب پمپ	قدرت		جریان A	قطر پروانه D (mm)	قطر فلاج پمپ (mm)		آبدهی (m ³ /h)														
	KW	HP			رایش	مکش		40	60	70	80	90	100	120	130	140	150	160	170	180	190
NF4 100-200 E	4	5.5	9	170	100	125	H (m)	9.4	9.1	8.8	8.5	8.1	7.7	6.5	5.7	4.7	3.3	*	*	*	*
NF4 100-200 D	5.5	7.5	12	180	100	125		10.5	10.2	10	9.8	9.5	9.2	8.2	7.6	6.8	5.6	*	*	*	*
NF4 100-200 C	5.5	7.5	12	190	100	125		11.8	11.6	11.4	11.2	11	10.7	10	9.4	8.6	7.5	6.3	*	*	*
NF4 100-200 B	7.5	10	16	200	100	125		13.3	13.1	13	12.8	12.6	12.4	11.8	11.3	10.6	9.8	8.7	7.5	*	*
NF4 100-200 A	7.5	10	16	209	100	125		14.8	14.7	14.7	14.6	14.5	14.3	13.8	13.3	12.7	11.9	11.1	10.2	9.1	7.6

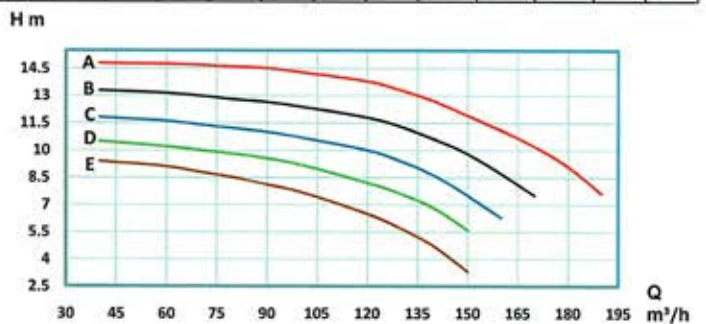
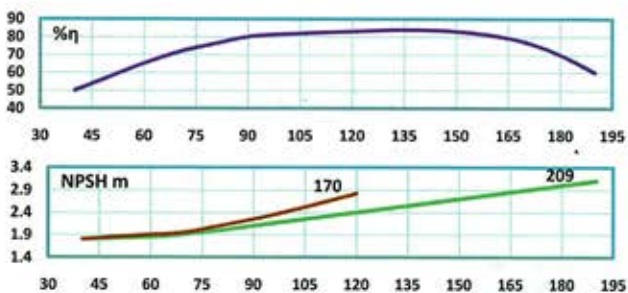

NF 4 1450 rpm

نوب پمپ	قدرت		جریان A	قطر پروانه D (mm)	قطر فلاح پمپ (mm)		آبدهی (m ³ /h)	H (m)													
	KW	HP			راشش	مکنش		40	60	70	80	90	100	120	130	140	150	160	170	180	190
NF4 100-250 E	5.5	7.5	12	220	100	125	H (m)	16	15.5	15	14.4	13.6	12.7	10.6	9.5	*	*	*	*	*	*
NF4 100-250 D	7.5	10	16	230	100	125		17.6	17	16.6	16.1	15.5	14.8	13	12	10.7	*	*	*	*	*
NF4 100-250 C	11	15	22	240	100	125		19.4	18.7	18.4	18	17.5	16.9	15.4	14.4	13.2	11.7	10.2	*	*	*
NF4 100-250 B	11	15	22	250	100	125		21	20.4	20.1	19.7	19.2	18.7	17.4	16.6	15.5	14.4	13	11.4	9.5	*
NF4 100-250 A	11	15	22	259	100	125		22.5	22.1	21.8	21.43	21	20.5	19.2	18.5	17.6	16.7	15.5	14.1	12.6	10.8

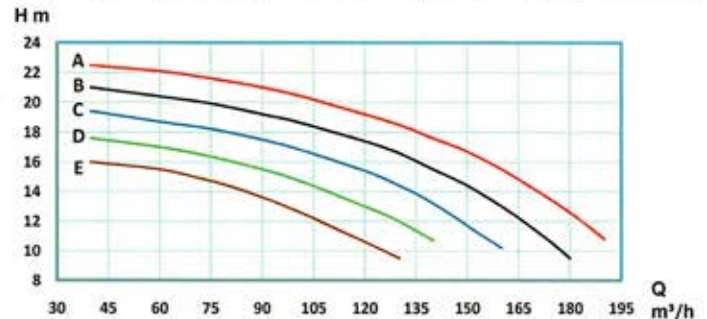
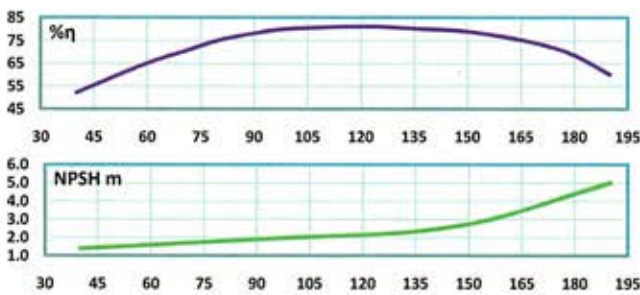

نوب پمپ	قدرت		جریان A	قطر پروانه D (mm)	قطر فلاح پمپ (mm)		آبدهی (m ³ /h)	H (m)													
	KW	HP			راشش	مکنش		40	60	70	80	90	100	120	140	150	160	170	180	190	205
NF4 100-315 F	11	15	22	270	100	125	H (m)	25.8	25	24.5	24	23.4	22.5	19.8	15.5	13	*	*	*	*	*
NF4 100-315 E	15	20	29	280	100	125		28	27.2	26.9	26.5	26	25.3	23	19.1	16.8	*	*	*	*	*
NF4 100-315 D	15	20	29	290	100	125		29.5	29	28.7	28.4	27.9	27.2	25	21.7	19.5	17	14	*	*	*
NF4 100-315 C	18.5	25	38	300	100	125		31.5	31.1	30.9	30.5	30.1	29.5	27.7	25.2	23.5	21.6	19	16	*	*
NF4 100-315 B	22	30	43.5	310	100	125		34.5	34.3	34.2	34	33.6	33	31.5	29.3	28	26.5	24.7	22.1	19.6	*
NF4 100-315 A	22	30	43.5	319	100	125	36.2	36	35.9	35.7	35.5	35.1	34	32.1	31	29.7	28	26	23.5	19.5	

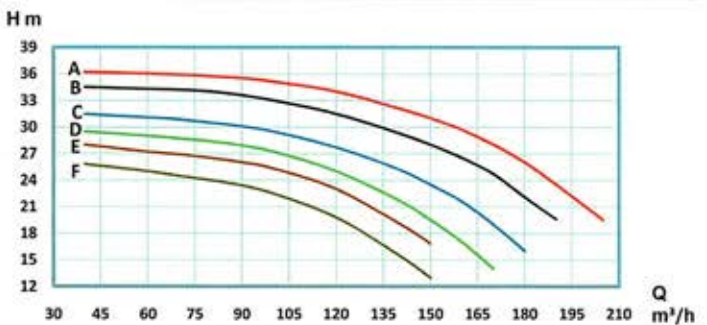
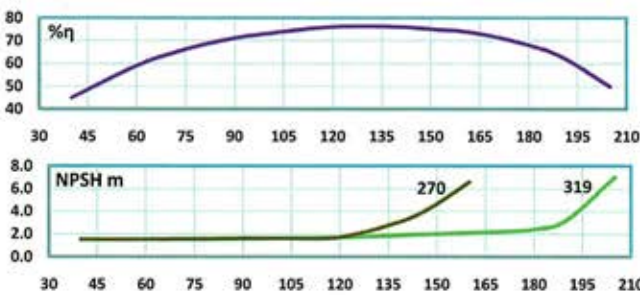

نوب پمپ	قدرت		جریان A	قطر پروانه D (mm)	قطر فلاح پمپ (mm)		آبدهی (m ³ /h)	H (m)													
	KW	HP			راشش	مکنش		40	60	70	80	90	100	120	150	160	170	180	190	200	210
NF4 100-400 F	15	20	29	320	100	125	H (m)	36	35.9	35.6	35	34.1	33	29.9	22	19	*	*	*	*	*
NF4 100-400 E	22	30	43.5	340	100	125		41	40.5	40	39.4	38.5	37.6	35	28.8	26	*	*	*	*	*
NF4 100-400 D	30	41	58	360	100	125		46	45.6	45.4	45	44.4	43.5	41	36.5	34.5	*	*	*	*	*
NF4 100-400 C	37	50	71	380	100	125		51	50.5	50.1	49.7	49.1	48.5	46.9	43	41.2	39	36.6	33.5	30	*
NF4 100-400 B	37	50	71	400	100	125		56.5	56.2	56.1	55.9	55.5	55	53.5	50.4	49	47	44.9	42	39	36
NF4 100-400 A	45	60	87	404	100	125	57.5	57.3	57.2	57	56.6	56.1	54.8	52	50.5	48.7	46.5	43.8	41	38	

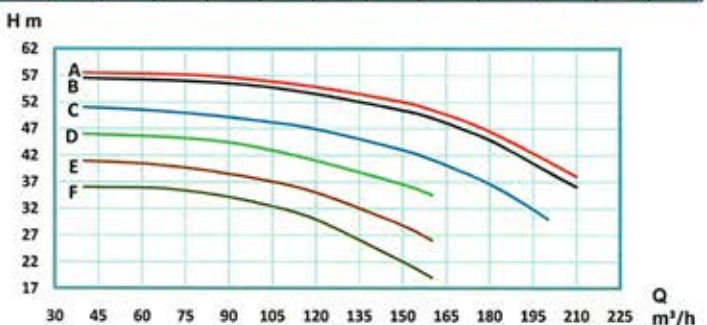
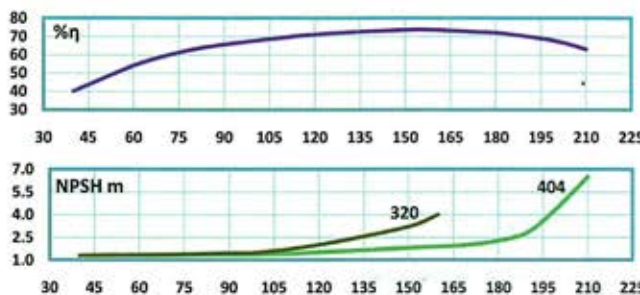

NF 4 1450 rpm

نوب پمپ	قدرت		جریان A	قطر پروانه D (mm)	قطر فلاج پمپ (mm)		ابدهی (m ³ /h)	50	75	100	125	150	175	200	225	235	240	250	260	270	280	
	KW	HP			راش	مکش		H (m)														
NF4 125-200 E	5.5	7.5	12	170	150	125	H (m)	9	8.9	8.6	8	6.8	*	*	*	*	*	*	*	*	*	*
NF4 125-200 D	7.5	10	16	180	150	125		10.1	10	9.8	9.3	8.4	7.2	6	*	*	*	*	*	*	*	*
NF4 125-200 C	7.5	10	16	190	150	125		11.4	11.3	11.1	10.8	10.2	9.2	7.9	*	*	*	*	*	*	*	*
NF4 125-200 B	11	15	22	200	150	125		12.6	12.5	12.4	12.1	11.6	10.9	9.8	8.5	7.8	7.4	6.5	*	*	*	*
NF4 125-200 A	11	15	22	209	150	125		13.8	13.8	13.7	13.5	13.1	12.5	11.6	10.4	9.8	9.5	8.8	8	7	6	6

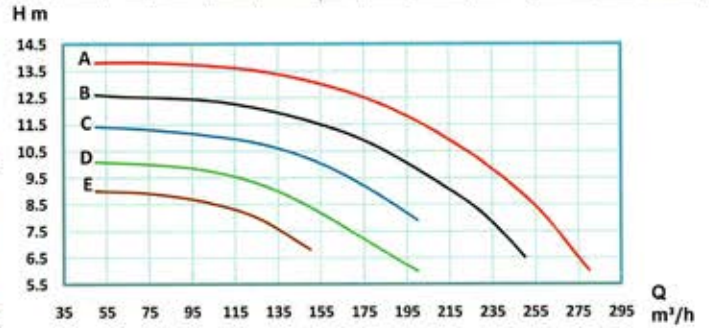
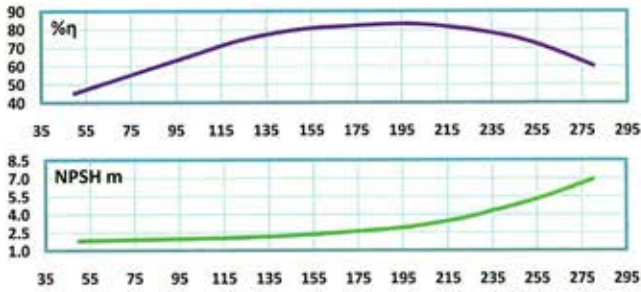

نوب پمپ	قدرت		جریان A	قطر پروانه D (mm)	قطر فلاج پمپ (mm)		ابدهی (m ³ /h)	50	75	100	125	150	175	200	225	235	250	260	275	300	330
	KW	HP			راش	مکش		H (m)													
NF4 125-250 F	9.2	12.5	18.5	210	150	125	H (m)	15	14.8	14.5	14	13.3	12.2	11	9.5	8.9	7.8	6.8	*	*	*
NF4 125-250 E	11	15	22	220	150	125		16.4	16.1	15.8	15.3	14.7	13.7	12.5	11.1	10.5	9.3	8.4	*	*	*
NF4 125-250 D	15	20	29	230	150	125		18	17.7	17.4	16.8	16.1	15.1	14	12.5	11.9	11	10.3	9.1	*	*
NF4 125-250 C	15	20	29	240	150	125		19.8	19.6	19.3	18.8	18.1	17.2	16.1	14.7	14.1	13.1	12.4	11.1	9	*
NF4 125-250 B	18.5	25	38	250	150	125		21.8	21.5	21.2	20.8	20.2	19.4	18.4	17.1	16.5	15.5	14.8	13.7	11.7	*
NF4 125-250 A	18.5	25	38	259	150	125		23.2	23.1	22.9	22.6	22.2	21.5	20.5	19.2	18.6	17.7	17.1	16.1	14.3	11.5

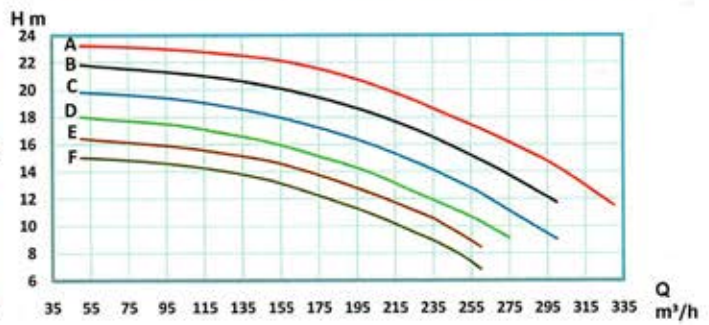
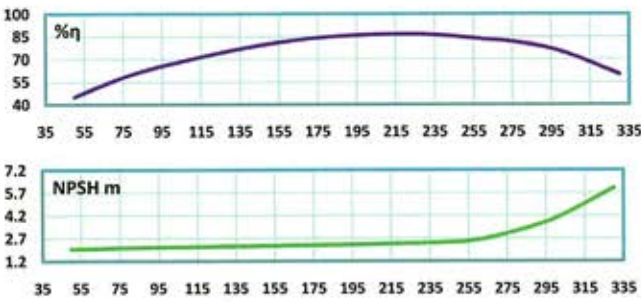

نوب پمپ	قدرت		جریان A	قطر پروانه D (mm)	قطر فلاج پمپ (mm)		ابدهی (m ³ /h)	50	75	100	125	150	175	200	225	235	250	260	275	300	330	
	KW	HP			راش	مکش		H (m)														
NF4 125-315 F	15	20	29	270	150	125	H (m)	24.5	24.2	23.8	23	21.8	20	17.5	*	*	*	*	*	*	*	*
NF4 125-315 E	18.5	25	38	280	150	125		26.7	26.4	26	25.3	24.2	22.6	20.5	17.5	*	*	*	*	*	*	*
NF4 125-315 D	22	30	43.5	290	150	125		28.7	28.4	28	27.4	26.5	25.1	23.2	20.6	19.4	17.7	*	*	*	*	*
NF4 125-315 C	30	41	58	300	150	125		30.7	30.4	30.1	29.5	28.8	27.5	25.9	23.6	22.6	21.2	*	*	*	*	*
NF4 125-315 B	30	41	58	310	150	125		33	32.7	32.3	31.8	31.2	30.1	28.7	26.8	25.9	24.5	*	*	*	*	*
NF4 125-315 A	30	41	58	319	150	125		35.5	35.2	34.7	34.1	33.4	32.4	31	29.1	28.3	27	26	24.4	21.5	*	

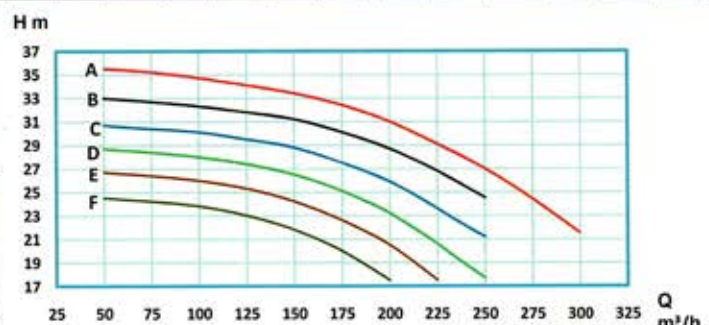
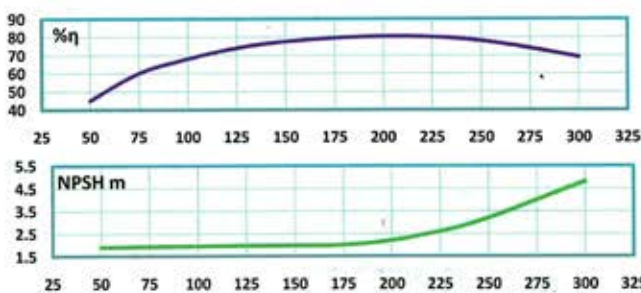

NF 4 1450 rpm

نوب پمپ	قدرت		جریان A	قطر پروانه D (mm)	قطر فلاج پمپ (mm)		اندهی (m ³ /h)	50	75	100	125	150	175	200	225	235	250	260	275	300	330	
	KW	HP			راشش	مکنش																
NF4 125-400 F	22	30	43.5	320	150	125	H (m)	36	35.5	34.8	33.1	31	27.2	23	17.2	15	*	*	*	*	*	*
NF4 125-400 E	30	41	58	340	150	125		41	40.9	40.3	38.9	37	34	30.5	25	22.2	18	15	*	*	*	*
NF4 125-400 D	37	50	71	360	150	125		46	45.5	45	43.8	42.2	39.9	37.2	32.8	30.5	26.5	23	18	*	*	*
NF4 125-400 C	45	60	87	380	150	125		51	50.5	50	49	48	45.9	43.6	40.5	38.8	35.5	32.9	28	20	*	*
NF4 125-400 B	55	75	104	400	150	125		56.5	56	55.5	54.6	53.5	51.8	50	47	45.8	43.8	42	38.7	32	22.5	*
NF4 125-400 A	55	75	104	404	150	125		58	57.5	57	56	55	53.5	51.7	48.8	47.6	45.5	44	40.6	34	24.5	*

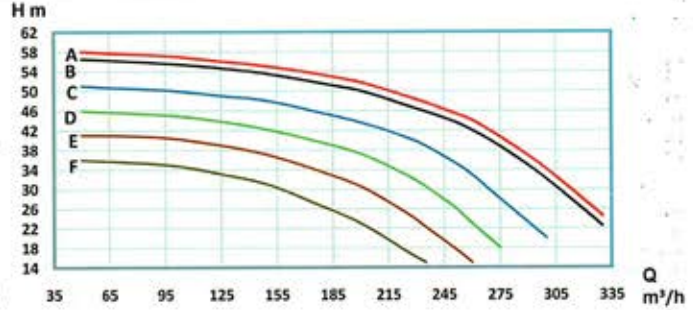
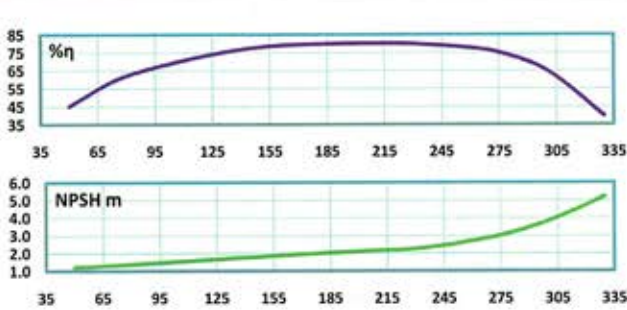

نوب پمپ	قدرت		جریان A	قطر پروانه D (mm)	قطر فلاج پمپ (mm)		اندهی (m ³ /h)	100	150	200	225	250	275	300	325	350	375	400	410	420	425	
	KW	HP			راشش	مکنش																
NF4 150-200 G	5.5	7.5	12	190/110	200	150	H (m)	6	5.7	5.3	5	4.7	4.3	*	*	*	*	*	*	*	*	*
NF4 150-200 F	7.5	10	16	200/130	200	150		7.2	6.9	6.5	6.3	6	5.7	5.3	4.9	*	*	*	*	*	*	*
NF4 150-200 E	7.5	10	16	200/150	200	150		8.3	7.9	7.5	7.2	6.9	6.5	6.1	5.7	5.3	*	*	*	*	*	*
NF4 150-200 D	11	15	22	209/156	200	150		9.2	8.8	8.3	8	7.7	7.3	6.9	6.4	5.8	*	*	*	*	*	*
NF4 150-200 C	11	15	22	209/190	200	150		10.7	10.3	9.7	9.4	9	8.6	8.1	7.5	7	6.3	5.5	5.2	*	*	
NF4 150-200 B	11	15	22	209/200	200	150		11.9	11.4	10.7	10.3	9.9	9.4	9	8.4	7.7	7.1	6.4	6.1	*	*	
NF4 150-200 A	15	20	29	209	200	150	13.2	12.6	11.8	11.3	10.8	10.3	9.7	9.1	8.5	7.9	7.2	6.9	6.6	6.4	*	

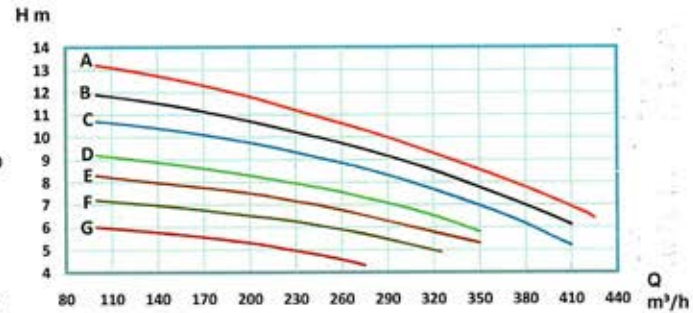
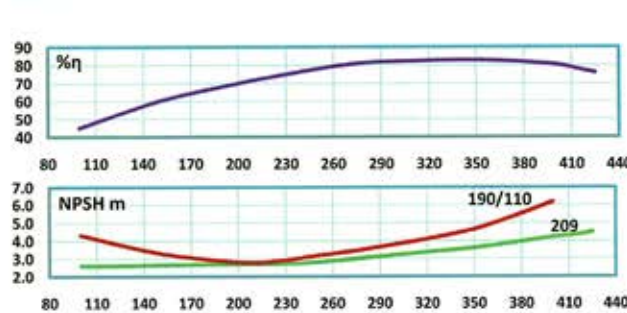

نوب پمپ	قدرت		جریان A	قطر پروانه D (mm)	قطر فلاج پمپ (mm)		اندهی (m ³ /h)	100	150	200	250	300	325	350	375	400	425	450	475	500	510
	KW	HP			راشش	مکنش															
NF4 150-250 F	11	15	22	225/176	200	150	H (m)	12.5	12.1	11.5	10.7	9.5	8.8	8	7.2	*	*	*	*	*	*
NF4 150-250 E	15	20	29	235/207	200	150		15.3	14.9	14.4	13.5	12.3	11.6	10.8	10	9.2	8.2	*	*	*	*
NF4 150-250 D	18.5	25	38	240/223	200	150		16.9	16.5	16	15	13.8	13.1	12.4	11.6	10.7	9.7	*	*	*	*
NF4 150-250 C	18.5	25	38	245/235	200	150		18.2	17.8	17.3	16.5	15.4	14.8	14	13.1	12.2	11.3	10.4	*	*	*
NF4 150-250 B	22	30	43.5	250	200	150		19.7	19.5	19	18.2	17.2	16.5	15.8	15	14.1	13.2	12.2	11	*	*
NF4 150-250 A	30	41	58	259	200	150		21.3	21.2	20.8	20.1	19.2	18.6	18	17.3	16.5	15.6	14.6	13.6	12.5	12

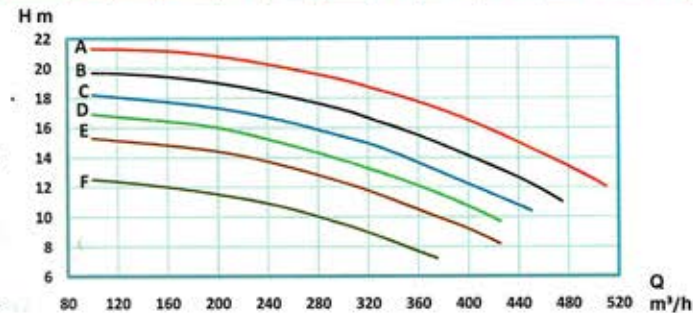
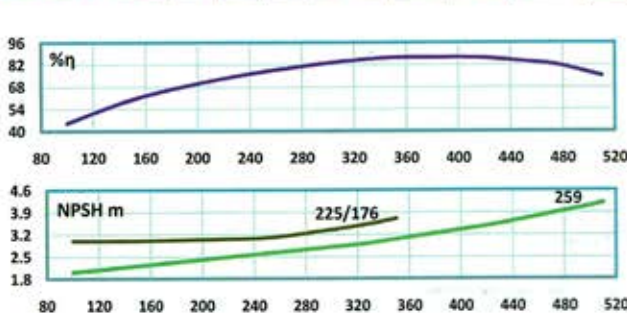

NF 4 1450 rpm

نیم پمپ	قدرت		جریان A	قطر بروانه D (mm)	قطر فلانچ پمپ (mm)		ابدهی (m ³ /h)	50	75	100	150	200	250	275	300	325	350	375	400	450	475
	KW	HP			راستی	چپ		H (m)													
NF4 150-315 F	22	30	43.5	270	200	150	H (m)	24.8	24.5	24.2	23.3	22.3	20.6	19.5	18	16	14	*	*	*	*
NF4 150-315 E	22	30	43.5	280	200	150		26.8	26.5	26.2	25.6	24.8	23.3	22.3	21	19.5	17.5	15	*	*	*
NF4 150-315 D	30	41	58	290	200	150		28.4	28.2	28	27.5	26.6	25.2	24.3	23	21.6	20	18.2	16.5	*	*
NF4 150-315 C	30	41	58	300	200	150		30	29.8	29.6	29.1	28.4	27.3	26.5	25.5	24.3	23	21.5	20	*	*
NF4 150-315 B	37	50	71	310	200	150		32.1	31.9	31.8	31.5	31	30	29.1	28.2	27.2	26.2	24.9	23.4	19.5	*
NF4 150-315 A	37	50	71	319	200	150		33.8	33.7	33.6	33.3	32.8	32	31.3	30.5	29.6	28.6	27.4	26	22.5	20.5

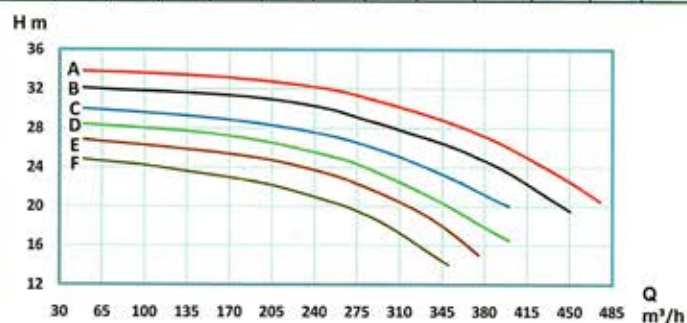
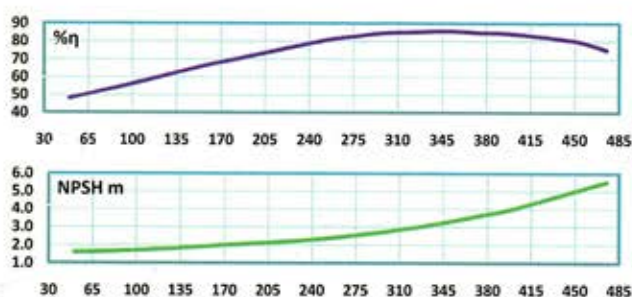

نیم پمپ	قدرت		جریان A	قطر بروانه D (mm)	قطر فلانچ پمپ (mm)		ابدهی (m ³ /h)	100	150	200	250	300	325	350	375	400	450	475	500	520	560
	KW	HP			راستی	چپ		H (m)													
NF4 150-400 E	30	41	58	320	200	150	H (m)	35	34.6	33.8	32	29	27	25	23	21	*	*	*	*	*
NF4 150-400 D	55	75	104	340	200	150		40	39.5	38.8	37	34	32.2	30.5	28.5	26.5	22	*	*	*	*
NF4 150-400 C	75	100	142	360	200	150		44.5	44.4	43.5	42	39.3	37.6	36	34	32	27	24.5	22	*	*
NF4 150-400 B	75	100	142	380	200	150		49.6	49.5	48.9	47.5	45.7	44.4	42.9	40.9	38.8	34.5	31.8	28.6	26	*
NF4 150-400 A	90	125	168	404	200	150		56.5	56.2	55.5	54	52	50.8	49.6	48.2	46.6	42.3	40.1	37.3	34.7	29.9

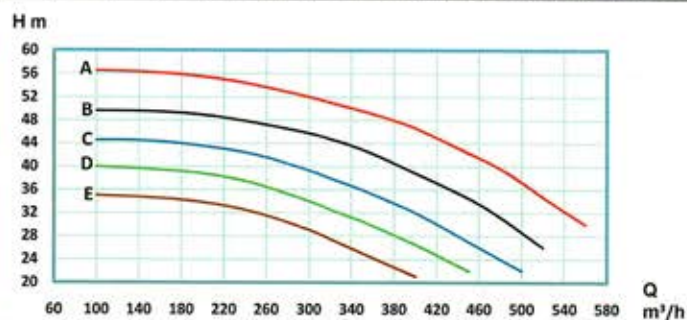
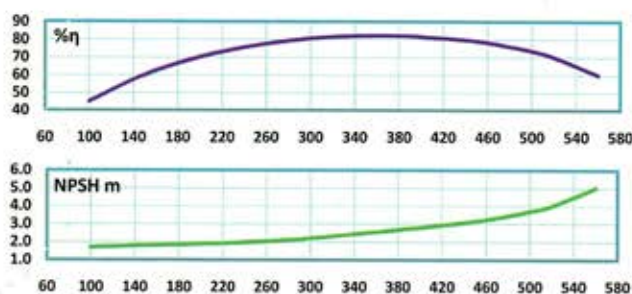

NF 2900 rpm

نیم پمپ	قدرت		حجم	قطر پروانه	قطر فلاح پمپ (mm)		انرژی	5	10	12	13	14	15	16	18	20	22	25	26	28	31
	KW	HP			A	D (mm)															
NF 32-160 E	2.2	3	5	130	32	50	H (m)	23	21.7	20.8	20.2	19.4	18.4	17.2	14.8	*	*	*	*	*	*
NF 32-160 D	3	4	6	140	32	50		27	25.8	24.9	24.3	23.6	22.9	22	20	17.8	15	*	*	*	*
NF 32-160 C	3	4	6	150	32	50		31	30.1	29.5	29	28.4	27.8	27.1	25.3	23.2	21	17	*	*	*
NF 32-160 B	4	5.5	8	160	32	50		35.5	35	34.4	34	33.6	33.1	32.5	31	29.4	27.3	24.1	22.8	19.8	*
NF 32-160 A	5.5	7.5	11	169	32	50		39.4	39	38.6	38.3	38	37.6	37.1	36.1	34.7	33.2	30.3	29.1	26.6	21.6

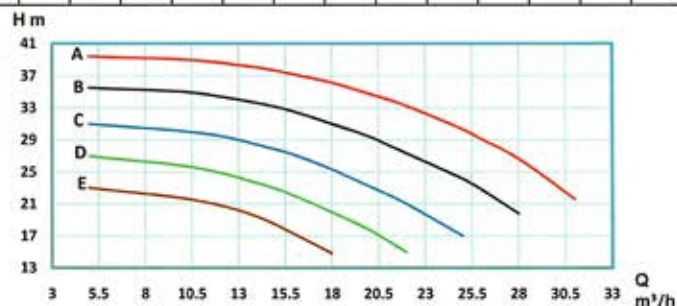
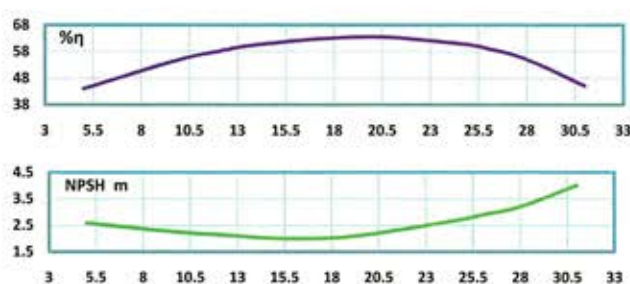

نیم پمپ	قدرت		حجم	قطر پروانه	قطر فلاح پمپ (mm)		انرژی	2	4	5	6	7	8	9	10	11	12	13	14	15	16
	KW	HP			A	D (mm)															
NF 32-200 E	3	4	6	170	32	50	H (m)	39.6	39	38.6	38.2	37.7	37.2	36.5	35.2	*	*	*	*	*	*
NF 32-200 D	4	5.5	8	180	32	50		45	44.5	44.1	43.7	43.2	42.7	42	40.9	39	36.5	*	*	*	*
NF 32-200 C	4	5.5	8	190	32	50		50	49.5	49.2	48.9	48.5	47.9	47.1	46.1	44.8	43	41	38.5	*	*
NF 32-200 B	5.5	7.5	11	200	32	50		55.7	55.2	55	54.6	54.3	53.8	53.3	52.5	51.4	49.9	48.1	46.1	43.5	*
NF 32-200 A	7.5	10	15	209	32	50		60.3	60.2	60.1	60	59.5	59.1	58.5	57.8	57	56	54.5	52.8	50.7	47.8

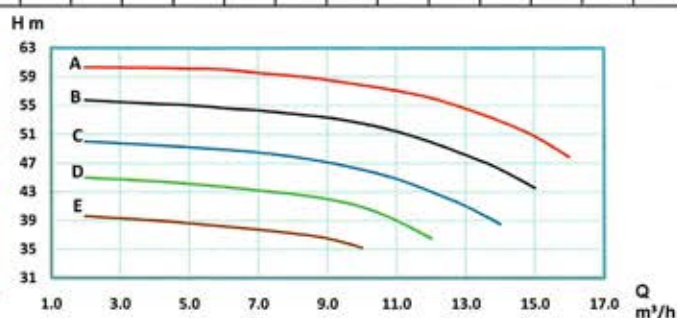
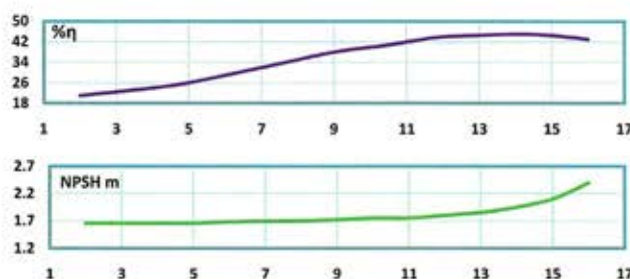

نیم پمپ	قدرت		حجم	قطر پروانه	قطر فلاح پمپ (mm)		انرژی	6	8	9	10	11	12	13	14	15	16	18	19	20	22
	KW	HP			A	D (mm)															
NF 32-250 F	7.5	10	15	210	32	50	H (m)	57.8	57	56.2	55.2	54	52	49.5	46	*	*	*	*	*	*
NF 32-250 E	11	15	22.5	220	32	50		63.9	63	62.3	61.3	60.3	59	57	54.5	51	47	*	*	*	*
NF 32-250 D	11	15	22.5	230	32	50		70	69.3	69	68.1	67	66	64.5	62.6	60	56.9	*	*	*	*
NF 32-250 C	11	15	22.5	240	32	50		76	75.2	74.7	74.2	73.5	73	72	70.9	69.2	66.8	60	*	*	*
NF 32-250 B	15	20	30	250	32	50		83	82.3	81.9	81.3	80.9	80.1	79.4	78.3	77	75.1	69.9	65.8	60	*
NF 32-250 A	15	20	30	259	32	50		89	88.5	88.1	87.5	87	86.4	85.9	85	84	82.7	79	75.9	71.4	58.9

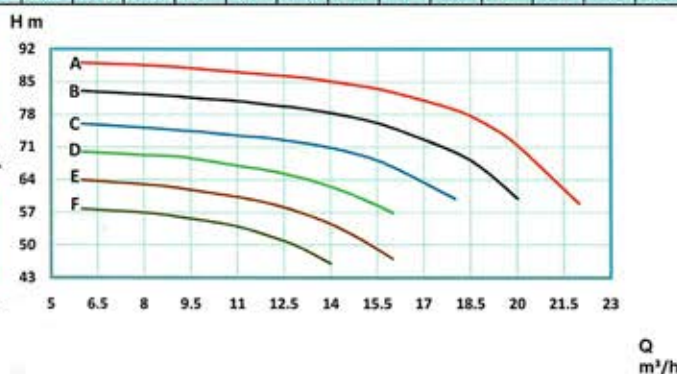
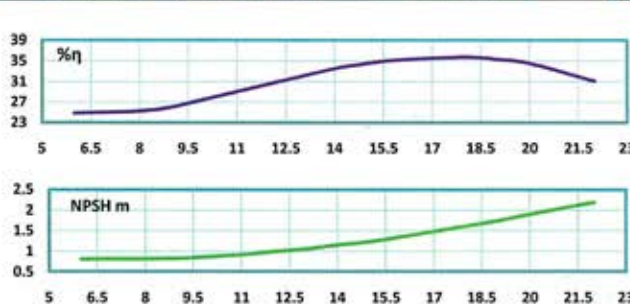

NF 2900 rpm

نیم پمپ	قدرت		جریان	قطر پروانه	قطر فلانچ پمپ (mm)		اندهی (m ³ /h)	10	13	15	18	20	23	25	28	30	33	35	38	40	43
	KW	HP			A	D (mm)															
NF 40-125 G	1.5	2	3	110	40	50	H (m)	14.5	14	13.5	12.9	12.2	11.3	10.2	8.8	7	*	*	*	*	*
NF 40-125 F	1.5	2	3	115	40	50		16.5	16	15.4	14.8	14.1	13.1	12	10.7	9	7	*	*	*	*
NF 40-125 E	2.2	3	5	120	40	50		18	17.6	17.2	16.7	16	15.2	14.2	13	11.3	9.3	7.1	*	*	*
NF 40-125 D	2.2	3	5	125	40	50		20.2	19.7	19.3	18.7	18	17.1	16.1	15	13.6	11.9	10	8	*	*
NF 40-125 C	3	4	6	130	40	50		21.9	21.5	21	20.4	19.7	18.9	18	17	15.6	14	12	10	*	*
NF 40-125 B	3	4	6	135	40	50		24	23.5	23	22.4	21.7	20.9	20	19	17.6	16.1	14.5	12.7	10.7	*
NF 40-125 A	3	4	6	139	40	50		25.5	25	24.5	23.9	23.2	22.4	21.5	20.5	19.3	18	16.5	14.9	13	10.5

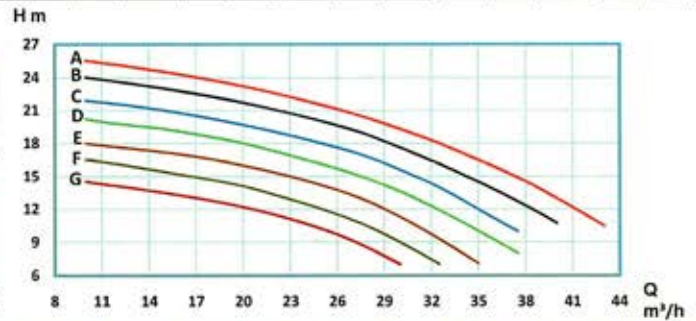
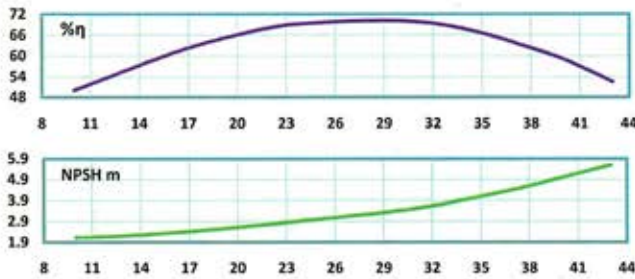

نیم پمپ	قدرت		جریان	قطر پروانه	قطر فلانچ پمپ (mm)		اندهی (m ³ /h)	10	13	15	18	20	23	25	28	30	33	35	38	40	42
	KW	HP			A	D (mm)															
NF 40-160 E	2.2	3	5	130	40	65	H (m)	23	22.5	21.6	20.2	18.3	16	*	*	*	*	*	*	*	*
NF 40-160 D	3	4	6	140	40	65		27	26.5	25.9	25	23.6	21.7	19	16	*	*	*	*	*	
NF 40-160 C	4	5.5	8	150	40	65		31	30.5	30	29.3	28.5	27.3	25.4	23	20.5	17.9	*	*	*	
NF 40-160 B	5.5	7.5	11	160	40	65		35.4	35	34.5	34.1	33.5	32.8	31.8	30.2	28	25.1	22	19	*	
NF 40-160 A	5.5	7.5	11	169	40	65		39.7	39.5	39	38.5	37.9	37.3	36.6	35.6	34	32	29.5	27	24	21.5

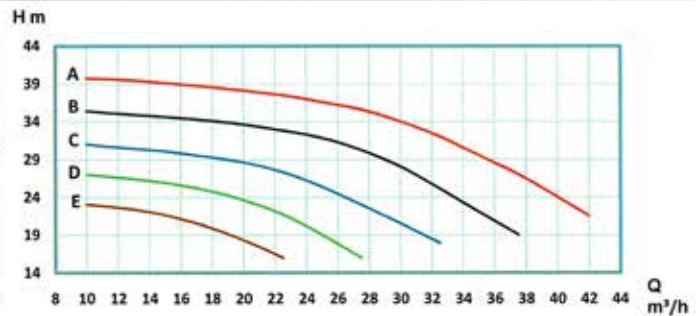
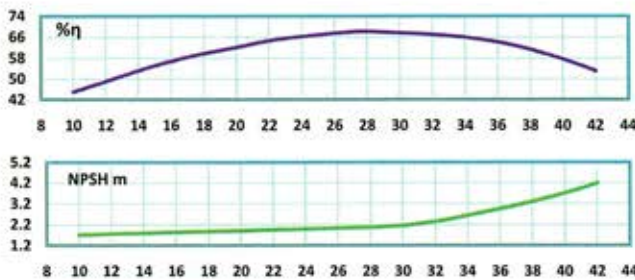

نیم پمپ	قدرت		جریان	قطر پروانه	قطر فلانچ پمپ (mm)		اندهی (m ³ /h)	5	10	13	15	18	20	22	23	25	28	30	33	35	39
	KW	HP			A	D (mm)															
NF 40-200 E	4	5.5	8	170	40	65	H (m)	39	38.4	37.6	36.3	34.5	32	30	28.5	24	*	*	*	*	*
NF 40-200 D	5.5	7.5	11	180	40	65		43.9	43	42.2	41.3	39.9	37.5	35.8	34.4	31	27	*	*	*	
NF 40-200 C	7.5	10	15	190	40	65		49	48.1	47.5	46.8	45.8	44.3	43	41.8	39	35.6	31.8	27.9	*	
NF 40-200 B	11	15	22.5	200	40	65		54.5	54	53.5	52.7	51.7	50.2	49.2	48.4	46.3	43.7	40	36	31	*
NF 40-200 A	11	15	22.5	209	40	65		59.5	59	58.7	58.2	57.6	56.5	55.7	55	53	50.9	48.1	44.9	40.9	33

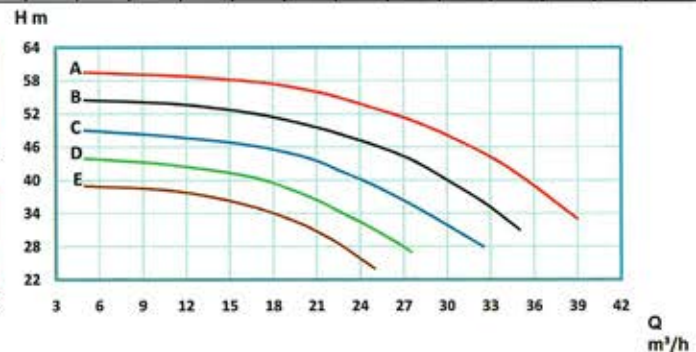
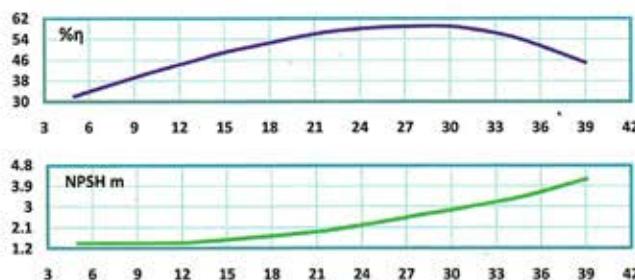

NF 2900 rpm

نوب پمپ	قدرت		جریان A	قطر پروانه D (mm)	قطر فلاج پمپ (mm)		اندھی (m ³ /h)	10	15	20	23	25	30	35	38	40	43	45	50	55	56
	KW	HP			راش	مکش															
NF 40-250 F	11	15	22.5	210	40	65	H (m)	58	57	55.6	54.9	54.2	52.5	49	46.7	44	40.2	*	*	*	*
NF 40-250 E	15	20	30	220	40	65		64.8	64	63	62.5	62	60	56.7	54.5	51.9	48.9	46	*	*	*
NF 40-250 D	15	20	30	230	40	65		71	70.5	69.5	69	68.5	67	64.1	61.9	59.4	56.7	53.5	47.5	*	*
NF 40-250 C	18.5	25	36	240	40	65		79.9	79	78	77.5	77	76	73	71	68.6	65.7	62.5	56	*	*
NF 40-250 B	22	30	42.5	250	40	65		87	86.5	86	85.5	85	83.9	81.8	80.1	78	75.6	73.1	67.6	60	58.3
NF 40-250 A	22	30	42.5	259	40	65		94	93.5	93	92.5	92	90.9	89	87.9	86.5	85	83	78.6	71.9	70.3

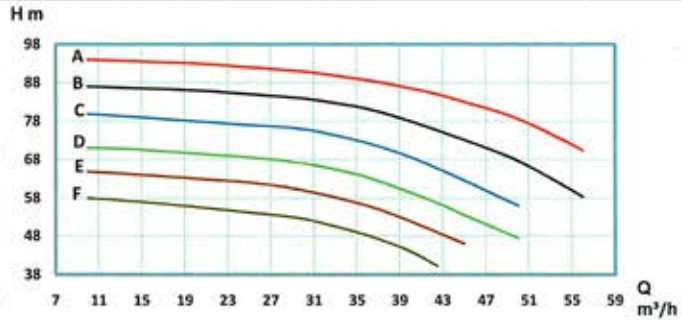
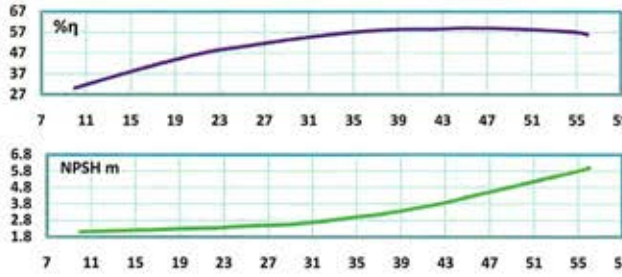

نوب پمپ	قدرت		جریان A	قطر پروانه D (mm)	قطر فلاج پمپ (mm)		اندھی (m ³ /h)	10	20	25	30	35	40	45	47.5	50	55	60	65	70	76
	KW	HP			راش	مکش															
NF 50-160 E	4	5.5	8	130	50	65	H (m)	21.7	21.2	20.9	20.3	19.5	18.4	17.2	*	*	*	*	*	*	*
NF 50-160 D	5.5	7.5	11	140	50	65		24.9	24.7	24.5	24	23.4	22.5	21.4	20.7	20.1	18.7	*	*	*	*
NF 50-160 C	7.5	10	15	150	50	65		28.5	28.4	28.2	28	27.7	27.2	26.4	25.9	25.3	23.9	21.9	*	*	*
NF 50-160 B	7.5	10	15	160	50	65		32.5	32.3	32.2	32	31.7	31.3	30.7	30.3	29.9	29	27.7	26.2	24.3	*
NF 50-160 A	11	15	22.5	169	50	65		36.6	36.4	36.2	36	35.7	35.3	34.8	34.5	34.2	33.5	32.6	31.5	30	28

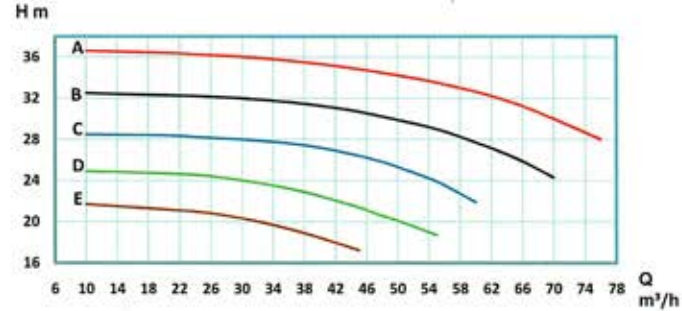
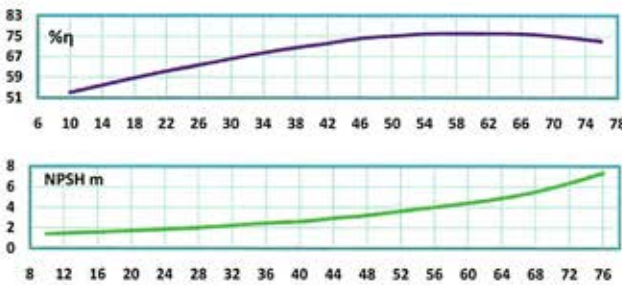

نوب پمپ	قدرت		جریان A	قطر پروانه D (mm)	قطر فلاج پمپ (mm)		اندھی (m ³ /h)	20	30	40	45	47.5	50	60	65	70	72.5	75	80	85	91
	KW	HP			راش	مکش															
NF 50-200 E	7.5	10	15	170	50	65	H (m)	37.3	36.5	34.5	33	32.1	30.9	25	*	*	*	*	*	*	*
NF 50-200 D	11	15	22.5	180	50	65		42.7	41.5	40	38.4	37.6	36.7	32.5	30	*	*	*	*	*	*
NF 50-200 C	11	15	22.5	190	50	65		47.5	46.6	45.5	44.3	43.6	42.8	39.5	37.5	35.1	33.6	31.8	*	*	*
NF 50-200 B	15	20	30	200	50	65		52.6	52	51.1	50.2	49.6	49	46.3	44.7	42.7	41.4	40	37.1	*	*
NF 50-200 A	18.5	25	36	209	50	65		57.7	57	56	55.4	55.1	54.7	52.5	51.1	49.5	48.5	47.4	45	42.5	38.5

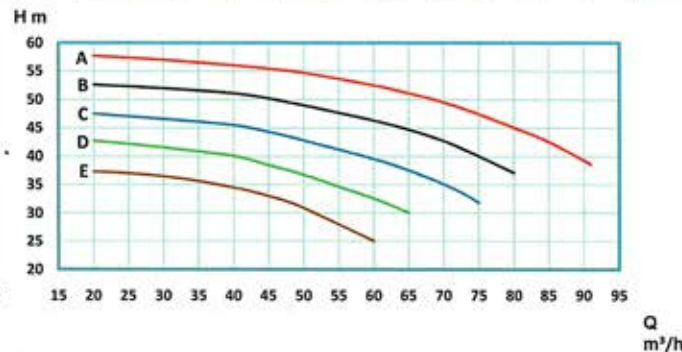
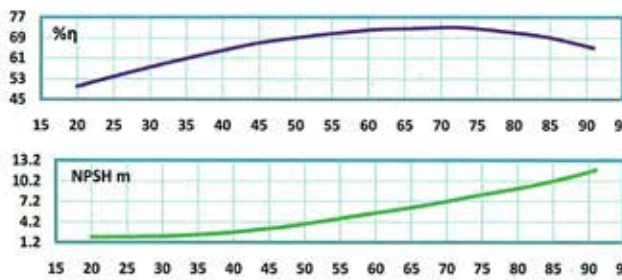

NF 2900 rpm

نوب پمپ	قدرت		جریان A	قطر پروانه D (mm)	قطر فلاج پمپ (mm)		اندھی (m ³ /h)	20	25	30	40	45	48	50	60	65	70	73	75	80	81	
	KW	HP			رانش	مکش		H (m)														
NF 50-250 E	15	20	30	220	50	65	H (m)	64.4	63.7	62.3	58.8	56.5	55.4	54	47.7	43.8	*	*	*	*	*	
NF 50-250 D	18.5	25	36	230	50	65		70.5	70	68.9	66	64	62.7	61.5	55	50.5	46	*	*	*	*	*
NF 50-250 C	18.5	25	36	240	50	65		76.8	76.1	75.1	72.8	70.9	69.9	68.7	62.4	58.7	54.3	52	49.8	*	*	
NF 50-250 B	22	30	42.5	250	50	65		84	83.7	83	80.9	79	77.7	76.3	70.1	66.7	62.4	60.1	57.9	53	52	
NF 50-250 A	30	41	57	259	50	65		91.2	90.9	90.3	88.2	86.5	85.5	84.3	78	74	70.1	68	66	61	60	

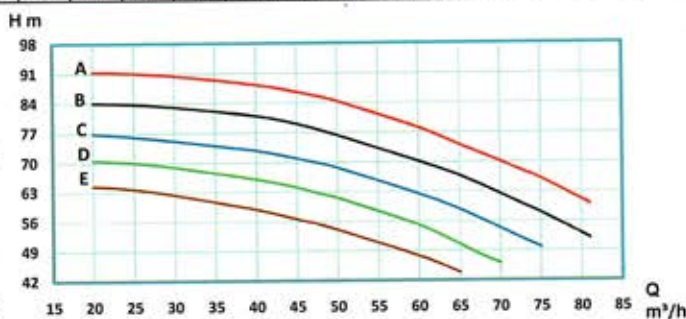
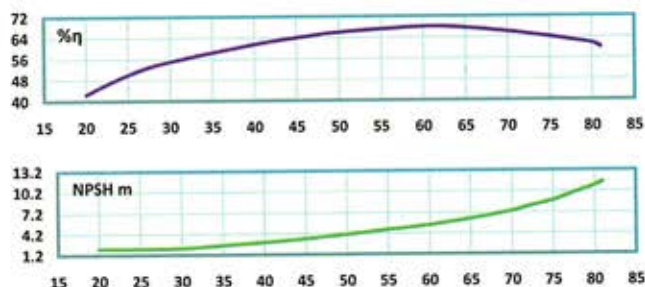

نوب پمپ	قدرت		جریان A	قطر پروانه D (mm)	قطر فلاج پمپ (mm)		اندھی (m ³ /h)	40	60	70	75	80	90	100	110	115	120	130	140	160	165
	KW	HP			رانش	مکش		H (m)													
NF 65-125 D	4	5.5	8	110	65	80	H (m)	13.4	12.2	11.3	10.7	10.1	8.6	7.1	5.3	4.5	*	*	*	*	*
NF 65-125 C	5.5	7.5	11	120	65	80		17	15.7	14.8	14.3	13.6	12.2	10.6	8.9	8	7	5	*	*	*
NF 65-125 B	7.5	10	15	130	65	80		20.5	19.5	18.9	18.5	18	17	15.5	13.8	12.9	12	9.8	7.5	*	*
NF 65-125 A	11	15	22.5	139	65	80		23.8	23.2	22.6	22.3	22	21.3	20.3	19.1	18.4	17.7	16.2	14.2	9.6	8.1

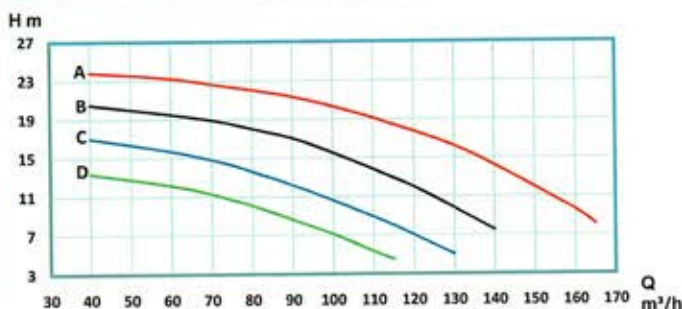
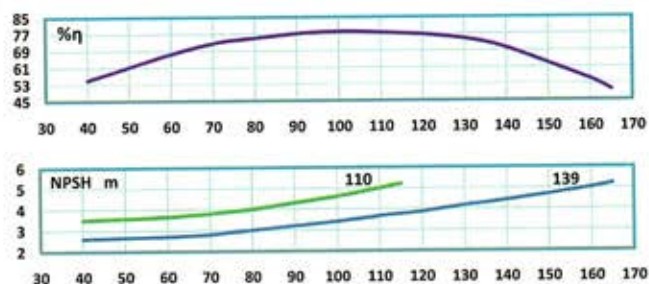

نوب پمپ	قدرت		جریان A	قطر پروانه D (mm)	قطر فلاج پمپ (mm)		اندھی (m ³ /h)	40	50	60	70	80	90	100	110	115	120	130	140	150	160
	KW	HP			رانش	مکش		H (m)													
NF 65-160 E	5.5	7.5	11	130	65	80	H (m)	20.5	19.8	19	17.6	15.9	14.1	12	9.5	*	*	*	*	*	*
NF 65-160 D	7.5	10	15	140	65	80		24.8	24.2	23.5	22.3	21	19.5	17.5	15.2	14	12.9	*	*	*	*
NF 65-160 C	11	15	22.5	150	65	80		29	28.2	27.5	26.4	25	23.4	21.5	19.5	18.3	17.2	14.8	*	*	*
NF 65-160 B	15	20	30	160	65	80		34.2	33.6	33	32.1	31.1	29.9	28.1	26.1	25.1	23.8	21	18	*	*
NF 65-160 A	15	20	30	169	65	80		38.9	38.5	37.9	37.1	36.1	34.9	33.5	31.9	31	30	27.5	25	22	19

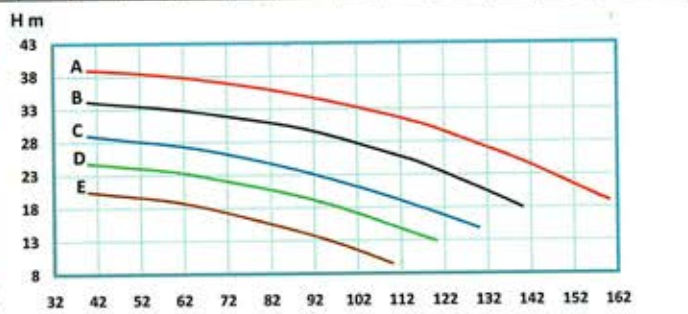
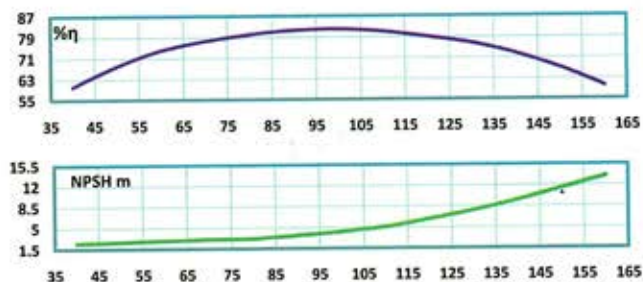

Q m³/h

NF 2900 rpm

نیم پمپ	قدرت		حریان	قطر پروانه	قطر فلانچ پمپ (mm)		اندازی (m ³ /h)	H (m)													
	KW	HP			A	D (mm)		راش	مکش	40	60	70	75	80	90	100	110	115	120	130	140
NF 65-200 E	15	20	30	170	65	80	H (m)	37.8	36.3	35	34	33	30.7	28	25.2	23.7	22	*	*	*	*
NF 65-200 D	15	20	30	180	65	80		42.5	41.3	39.9	38.9	37.8	35.5	32.9	29.9	28.5	27	24	*	*	*
NF 65-200 C	22	30	42.5	190	65	80		48	47	46	45.2	44.4	42.4	40.3	37.8	36.4	34.9	31.7	27.8	*	*
NF 65-200 B	22	30	42.5	200	65	80		53.5	52.5	51.5	51	50.2	48.5	46.2	43.3	41.8	40.2	37	33.5	30	*
NF 65-200 A	30	41	57	209	65	80		59	58.3	57.8	57.2	56.5	55	53.2	51	49.9	48.6	46.1	42.9	39.5	36

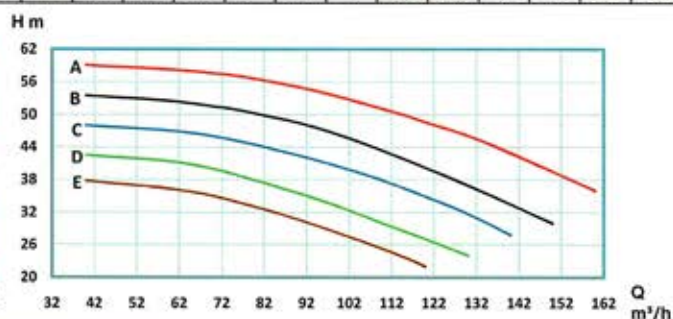
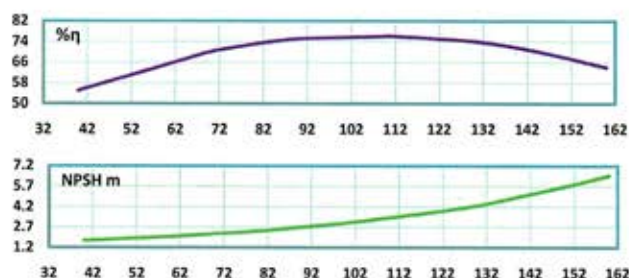

نیم پمپ	قدرت		حریان	قطر پروانه	قطر فلانچ پمپ (mm)		اندازی (m ³ /h)	H (m)													
	KW	HP			A	D (mm)		راش	مکش	40	60	70	75	80	90	100	110	120	130	140	150
NF 65-250 F	22	30	42.5	210	65	80	H (m)	60	58	57	56	55	52.7	50	46	41.5	36	30	*	*	*
NF 65-250 E	30	41	57	220	65	80		66	65	64	63.2	62.2	60	57.2	54	49.7	44.5	38	*	*	*
NF 65-250 D	37	50	69	230	65	80		72	70.8	69.6	68.8	67.9	66	63.7	60.9	57	52.3	46.8	40	*	*
NF 65-250 C	45	60	83	240	65	80		78	77	75.9	75.2	74.4	72.5	70.5	67.9	64.3	60.1	55	49	41.3	*
NF 65-250 B	45	60	83	250	65	80		86	85	84	83.5	83	81.6	79.7	77	73.4	69.2	64.9	59.9	53.9	46
NF 65-250 A	55	75	104	259	65	80		93	92	91.2	90.6	90	88.5	86.6	84	80.6	76.8	72.9	68	62.8	56.1

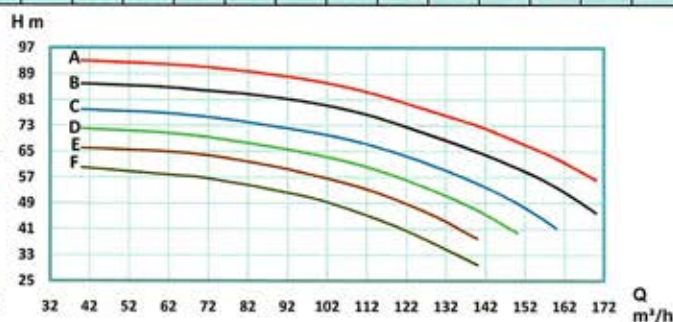
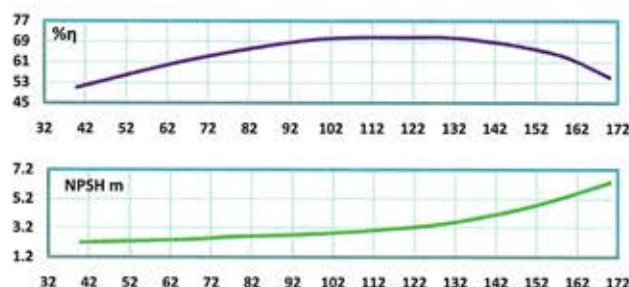

نیم پمپ	قدرت		حریان	قطر پروانه	قطر فلانچ پمپ (mm)		اندازی (m ³ /h)	H (m)													
	KW	HP			A	D (mm)		راش	مکش	50	80	100	120	135	150	160	170	180	200	220	240
NF 80-160 E	7.5	10	15	130	80	100	H (m)	18.9	18	17.1	15.9	14.7	13.1	12	10.7	9.5	*	*	*	*	*
NF 80-160 D	11	15	22.5	140	80	100		23.3	22.5	21.9	20.5	19.3	18	17	16	14.8	12.1	9	*	*	*
NF 80-160 C	15	20	30	150	80	100		27.7	27	26.2	25.1	24.1	22.9	22	21	19.9	17.2	14	*	*	*
NF 80-160 B	18.5	25	36	160	80	100		32.3	32	31.2	30	29	28	27.1	26.2	25.2	23	20	15.8	14.6	13.5
NF 80-160 A	22	30	42.5	169	80	100		36.3	36	35.5	34.7	34	33.1	32.4	31.7	30.8	28.5	25.6	21.6	20.5	19.5

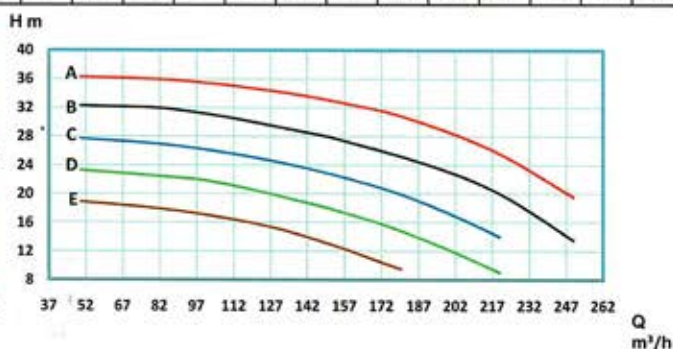
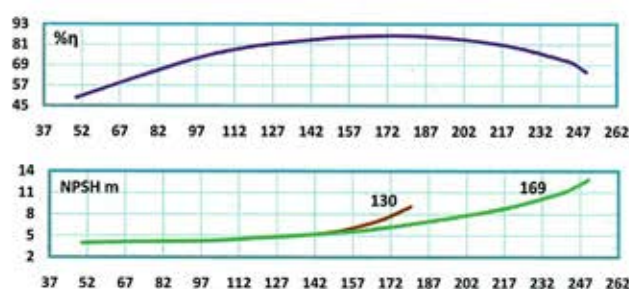

NF 2900 rpm

نوب پمپ	قدرت		جریان A	قطر پروانه D (mm)	قطر فلایج پمپ (mm)		آبدهی (m ³ /h)	50	80	100	110	120	135	150	160	180	200	220	240	245	250	
	KW	HP			رانس	مکس																
NF 80-200 E	18.5	25	36	170	80	100	H (m)	35.7	34.2	32.8	31.7	30.3	28	25	23	18.2	*	*	*	*	*	
NF 80-200 D	22	30	42.5	180	80	100		41.5	40	38.6	37.5	36.3	34.2	31.8	29.7	24.8	19.8	*	*	*	*	*
NF 80-200 C	30	41	57	190	80	100		46.9	45.6	44.5	43.8	42.7	41	38.5	36.5	31.9	27	22	*	*	*	
NF 80-200 B	30	41	57	200	80	100		52.5	51	49.8	49.1	48.1	46.5	44.6	43	39.1	35	29.9	24	22	*	
NF 80-200 A	37	50	69	209	80	100		58	56.8	55.8	55.1	54.1	52.6	50.8	49.4	46	42.4	37.7	31.5	29.9		

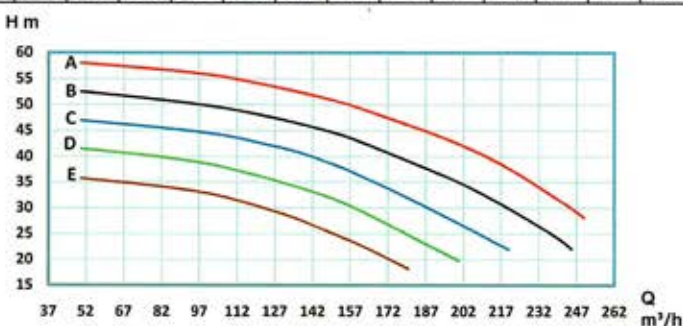
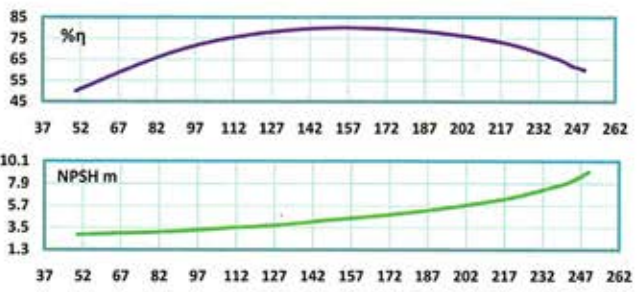

نوب پمپ	قدرت		جریان A	قطر پروانه D (mm)	قطر فلایج پمپ (mm)		آبدهی (m ³ /h)	50	80	100	110	120	135	150	160	180	200	220	240	245	250
	KW	HP			رانس	مکس															
NF 80-250 F	30	41	57	210	80	100	H (m)	57	56	54.5	53.7	52.4	50.5	48	46	41	33	*	*	*	*
NF 80-250 E	37	50	69	220	80	100		64.2	63.4	62	61	60	58	55.7	54	49.3	43.5	36	*	*	*
NF 80-250 D	45	60	83	230	80	100		71	70	68.5	67.7	66.8	65	63	61.2	57.4	52	46	39	*	*
NF 80-250 C	55	75	104	240	80	100		78	77	76.1	75.5	75	73.6	71.8	70.2	66.4	61.9	56	49	47	45
NF 80-250 B	75	100	140	250	80	100		85	84	83.1	82.5	82	80.8	79.1	77.9	74.8	71.2	66.5	60	58	56
NF 80-250 A	75	100	140	259	80	100		92	91	90	89.5	88.8	87.5	86	85	82.3	79.3	75.4	69.9	68.1	66.3

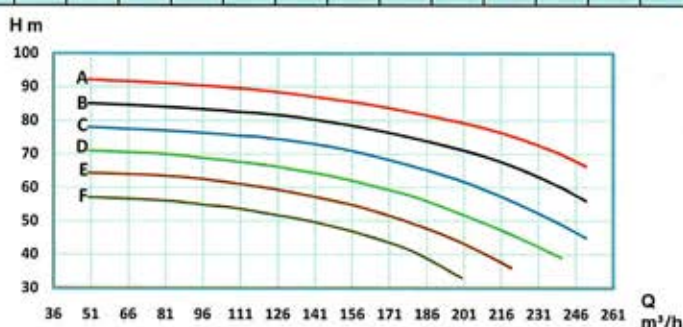
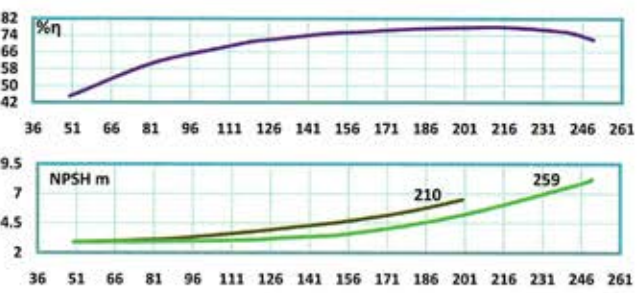

نوب پمپ	قدرت		جریان A	قطر پروانه D (mm)	قطر فلایج پمپ (mm)		آبدهی (m ³ /h)	100	125	150	175	200	225	250	260	275	300	325	340	350	380
	KW	HP			رانس	مکس															
NF 100-160 E	15	20	30	150/110	100	125	H (m)	18.7	18	17.1	16.1	15.1	14	12.9	12.4	11.6	*	*	*	*	*
NF 100-160 D	18.5	25	36	160/120	100	125		21.5	20.9	20.1	19.3	18.4	17.5	16.3	15.8	14.9	13	*	*	*	*
NF 100-160 C	22	30	42.5	169/130	100	125		25	24.5	23.9	23	22.1	21.2	20	19.5	18.6	16.8	15	14	*	*
NF 100-160 B	30	41	57	169/150	100	125		29	28.5	27.8	27.1	26.3	25.3	24	23.5	22.5	20.7	18.8	17.5	16.5	*
NF 100-160 A	30	41	57	169	100	125		32.5	32	31.5	30.8	30	29	27.9	27.4	26.6	25	23.2	22.1	21.3	18.9

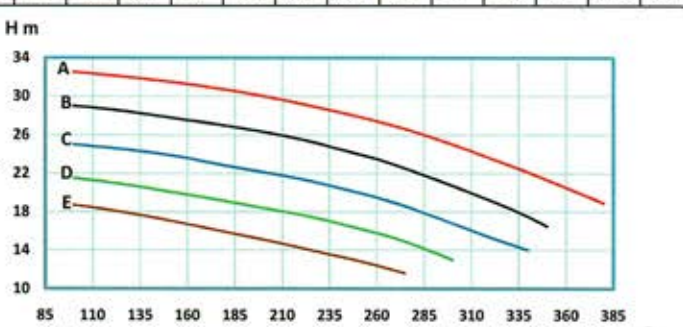
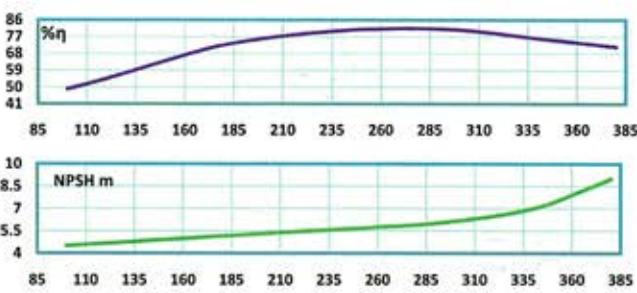

NF 2900 rpm

نوب پمپ	قدرت		جریان A	قطر پروانه D (mm)	قطر فلانچ پمپ (mm)		آبدهی (m ³ /h)	H (m)															
	KW	HP			راستی	مکس		50	100	125	150	175	200	225	250	270	275	300	325	350	380		
NF 100-200 E	30	41	57	170	100	125	H (m)	37	36	35	33.9	32.4	30.2	27.5	24	21	20	*	*	*	*		
NF 100-200 D	37	50	69	180	100	125		42.5	42	41.2	40.2	38.7	36.5	33.7	30.9	27.9	27	22.6	*	*	*		
NF 100-200 C	45	60	83	190	100	125		47.1	46.6	46.1	45.3	44.1	42.3	40	37.4	34.9	34.2	30	25	*	*		
NF 100-200 B	55	75	104	200	100	125		53.5	52.9	52.3	51.5	50.6	49	47	44.8	42.8	42.2	38.6	34.5	29.1	*		
NF 100-200 A	55	75	104	209	100	125		59.5	59	58.7	58.2	57.4	56.2	54.8	52.8	50.9	50.3	47	42.8	37.6	30.9		

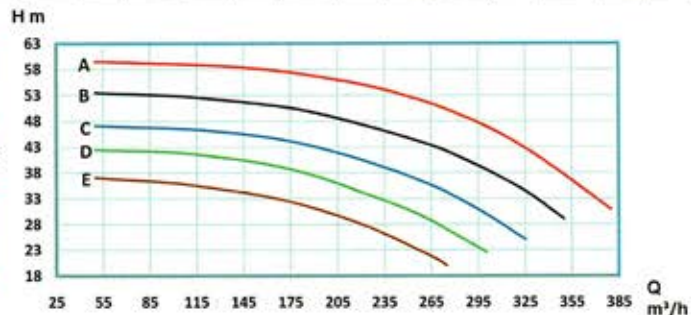
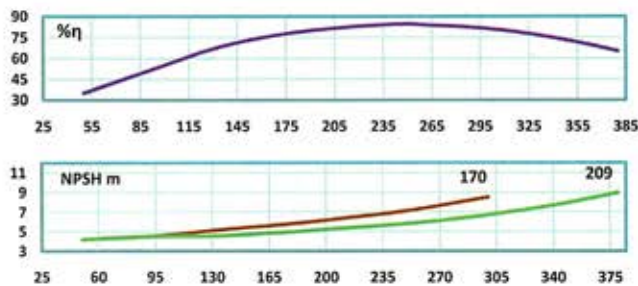

نوب پمپ	قدرت		جریان A	قطر پروانه D (mm)	قطر فلانچ پمپ (mm)		آبدهی (m ³ /h)	H (m)															
	KW	HP			راستی	مکس		50	100	125	150	175	200	225	250	260	275	300	325	350	390		
NF 100-250 E	45	60	83	220	100	125	H (m)	64	63	61.8	59.5	56	51.5	45.3	38.3	35.3	30	*	*	*	*		
NF 100-250 D	55	75	104	230	100	125		70.8	69	68	66	63	59.5	54.3	48.3	45.5	41	33.1	*	*	*		
NF 100-250 C	75	100	140	240	100	125		77	75.1	74	72.9	70.3	67	62.7	57.8	55.6	51.7	45	37	*	*		
NF 100-250 B	75	100	140	250	100	125		84	82.1	81	79.8	77.9	75.6	72	67	65	61.3	55.1	47.6	40	*		
NF 100-250 A	90	122	166	259	100	125		90	89	88	86.9	85.1	82.9	80	76.3	74.5	71.9	66.8	60	53	40		

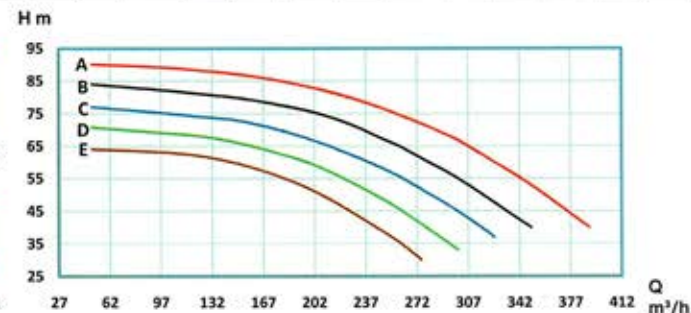
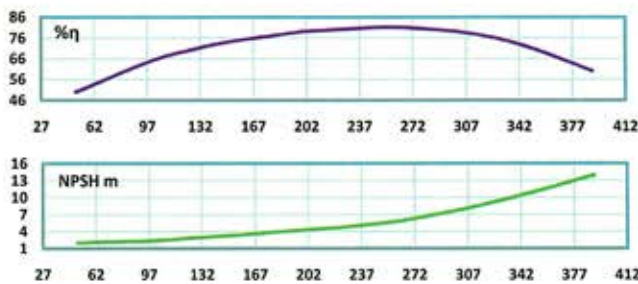

نوب پمپ	قدرت		جریان A	قطر پروانه D (mm)	قطر فلانچ پمپ (mm)		آبدهی (m ³ /h)	H (m)															
	KW	HP			راستی	مکس		100	150	175	200	225	250	275	300	325	350	400	425	450	490		
NF 125-200 E	37	50	69	170	125	150	H (m)	36.5	36	35.5	34.7	33.5	31.8	29.6	27.2	24	*	*	*	*	*		
NF 125-200 D	45	60	83	180	125	150		41	40.5	40	39.5	38.8	37.8	36	33.5	31	28.5	*	*	*	*		
NF 125-200 C	55	75	104	190	125	150		45.6	45.1	45	44.6	44	43.2	42	40	37.5	35	30	*	*	*		
NF 125-200 B	75	100	140	200	125	150		50.4	50.1	50	49.8	49.4	48.8	48	46.5	44.6	42.6	38.3	35.7	32.45	*		
NF 125-200 A	75	100	140	209	125	150		55.3	55	54.7	54.5	54	53.5	53	52.1	50.8	49	45.3	42.8	40.3	36		

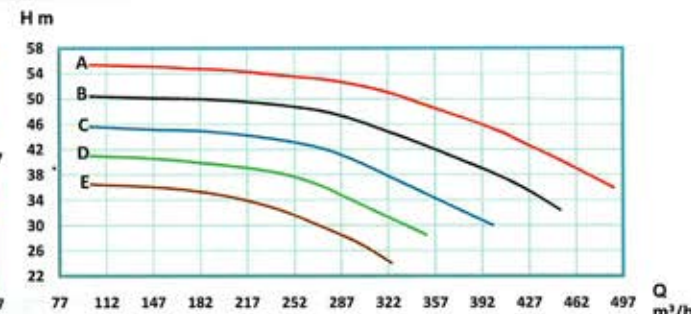
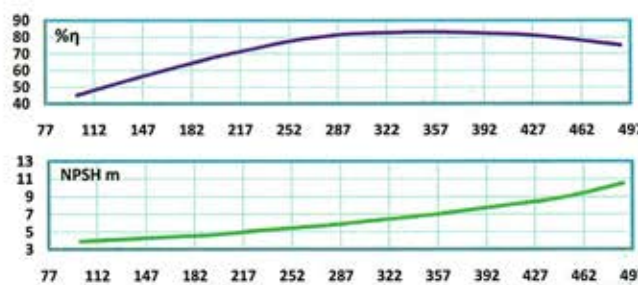

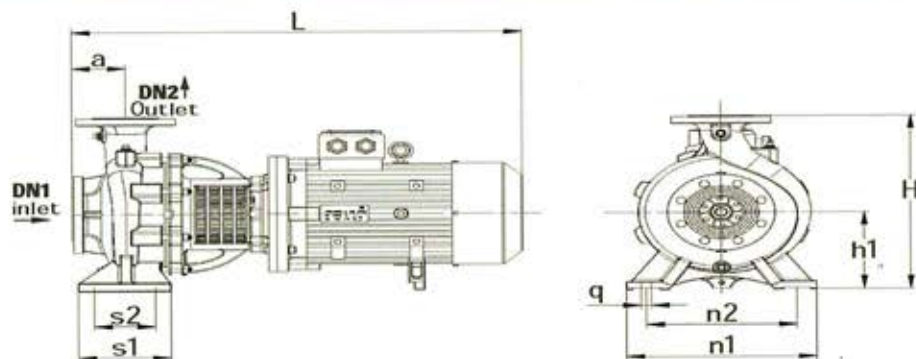

Type	L		DN1	DN2	a	s1	s2	n1	n2	q	h1	H
	1450 rpm	2900 rpm										
NF & NF4 32-160 E	520	560	50	32	80	100	70	240	190	14	132	292
NF & NF4 32-160 D	520	675										
NF & NF4 32-160 C	540	675										
NF & NF4 32-160 B	540	685										
NF & NF4 32-160 A	540	790										
NF & NF4 32-200 E	520	680	50	32	80	100	70	240	190	14	132	292
NF & NF4 32-200 D	540	690										
NF & NF4 32-200 C	540	690										
NF & NF4 32-200 B	540	790										
NF & NF4 32-200 A	540	790										
NF & NF4 32-250 F	540	820	50	32	100	125	95	320	250	14	180	405
NF & NF4 32-250 E	590	900										
NF & NF4 32-250 D	590	900										
NF & NF4 32-250 C	590	900										
NF & NF4 32-250 B	590	900										
NF & NF4 32-250 A	670	900										
NF & NF4 40-160 F	**	560	65	40	80	100	70	240	190	14	132	292
NF & NF4 40-160 E	520	560										
NF & NF4 40-160 D	520	650										
NF & NF4 40-160 C	540	675										
NF & NF4 40-160 B	540	675										
NF & NF4 40-160 A	540	675										
NF & NF4 40-200 E	570	720	65	40	100	100	70	265	212	14	160	340
NF & NF4 40-200 D	570	830										
NF & NF4 40-200 C	590	830										
NF & NF4 40-200 B	590	915										
NF & NF4 40-200 A	590	915										
NF & NF4 40-250 F	590	915	65	40	100	125	95	320	250	14	180	405
NF & NF4 40-250 E	590	915										
NF & NF4 40-250 D	705	915										
NF & NF4 40-250 C	705	915										
NF & NF4 40-250 B	705	1000										
NF & NF4 40-250 A	715	1000										

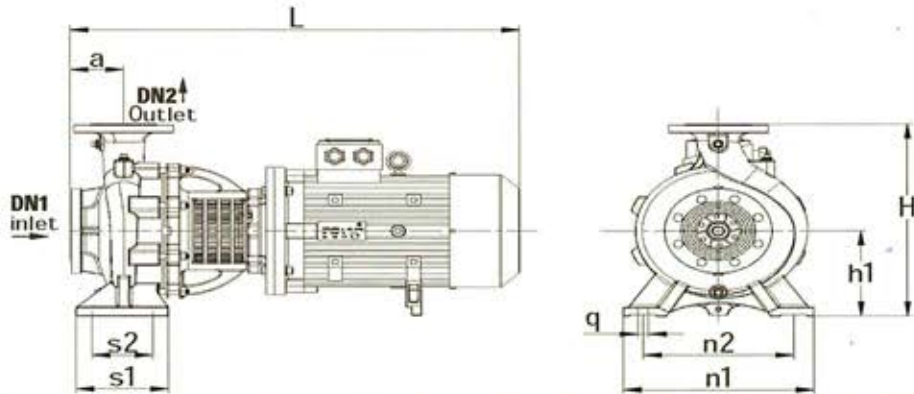

Type	L		DN1	DN2	a	s1	s2	n1	n2	q	h1	H
	1450 rpm	2900 rpm										
NF & NF4 40-315 F	755	**	65	40	125	125	95	345	280	14	225	475
NF & NF4 40-315 E	755	**										
NF & NF4 40-315 D	755	**										
NF & NF4 40-315 C	770	**										
NF & NF4 40-315 B	770	**										
NF & NF4 40-315 A	770	**										
NF & NF4 50-160 E	565	715	65	50	100	100	70	265	212	14	160	340
NF & NF4 50-160 D	565	820										
NF & NF4 50-160 C	565	820										
NF & NF4 50-160 B	590	820										
NF & NF4 50-160 A	590	900										
NF & NF4 50-200 E	590	720										
NF & NF4 50-200 D	590	900	65	50	100	100	70	265	212	14	160	360
NF & NF4 50-200 C	590	900										
NF & NF4 50-200 B	705	900										
NF & NF4 50-200 A	705	900										
NF & NF4 50-250 E	705	915										
NF & NF4 50-250 D	705	915										
NF & NF4 50-250 C	705	915	65	50	100	125	95	320	250	14	180	405
NF & NF4 50-250 B	705	960										
NF & NF4 50-250 A	720	1020										
NF & NF4 50-315 F	780	**										
NF & NF4 50-315 E	780	**										
NF & NF4 50-315 D	880	**										
NF & NF4 50-315 C	880	**	65	50	125	125	95	345	280	14	225	505
NF & NF4 50-315 B	880	**										
NF & NF4 50-315 A	880	**										
NF & NF4 65-160 E	570	825										
NF & NF4 65-160 D	600	825										
NF & NF4 65-160 C	600	900										
NF & NF4 65-160 B	600	900	80	65	100	125	95	280	212	14	160	360
NF & NF4 65-160 A	710	900										
NF & NF4 65-200 E	630	920										
NF & NF4 65-200 D	720	920										
NF & NF4 65-200 C	720	975										
NF & NF4 65-200 B	720	975										
NF & NF4 65-200 A	740	1035										

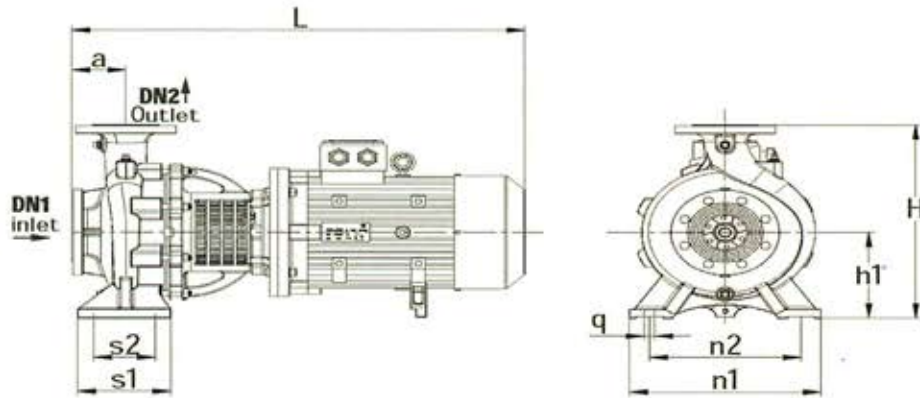

Type	L		DN1	DN2	a	s1	s2	n1	n2	q	h1	H
	1450 rpm	2900 rpm										
NF & NF4 65-250 F	740	990	80	65	100	160	120	360	280	18	200	450
NF & NF4 65-250 E	750	1050										
NF & NF4 65-250 D	850	1050										
NF & NF4 65-250 C	850	1150										
NF & NF4 65-250 B	850	1150										
NF & NF4 65-250 A	850	1210										
NF & NF4 65-315 F	775	**	80	65	125	160	120	400	315	18	225	505
NF & NF4 65-315 E	775	**										
NF & NF4 65-315 D	960	**										
NF & NF4 65-315 C	960	**										
NF & NF4 65-315 B	960	**										
NF & NF4 65-315 A	960	**										
NF & NF4 80-160 E	640	865	100	80	125	125	95	320	250	14	180	405
NF & NF4 80-160 D	640	950										
NF & NF4 80-160 C	750	950										
NF & NF4 80-160 B	750	950										
NF & NF4 80-160 A	750	1000										
NF & NF4 80-200 E	760	965	100	80	125	125	95	345	280	14	180	430
NF & NF4 80-200 D	760	1020										
NF & NF4 80-200 C	780	1075										
NF & NF4 80-200 B	780	1075										
NF & NF4 80-200 A	880	1075										
NF & NF4 80-250 F	780	1075	100	80	125	160	120	400	315	18	200	480
NF & NF4 80-250 E	880	1075										
NF & NF4 80-250 D	880	1170										
NF & NF4 80-250 C	880	1235										
NF & NF4 80-250 B	965	1370										
NF & NF4 80-250 A	965	1370										
NF & NF4 80-315 F	960	**	100	80	125	160	120	400	315	18	250	565
NF & NF4 80-315 E	960	**										
NF & NF4 80-315 D	965	**										
NF & NF4 80-315 C	965	**										
NF & NF4 80-315 B	965	**										
NF & NF4 80-315 A	1020	**										

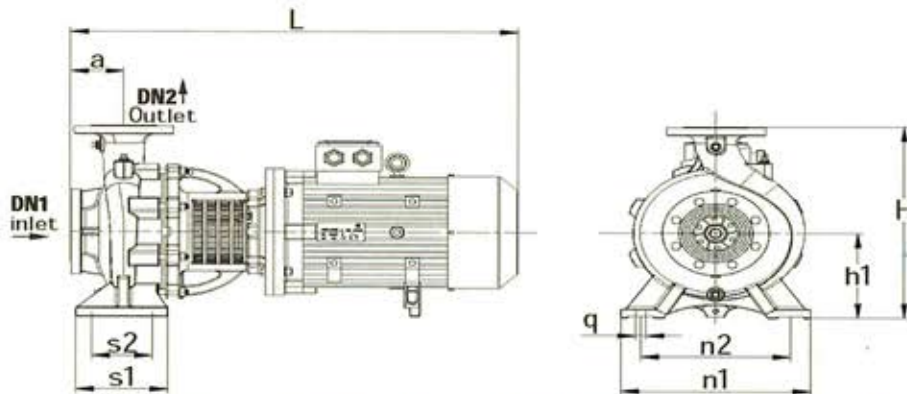

Type	L		DN1	DN2	a	s1	s2	n1	n2	q	h1	H
	1450 rpm	2900 rpm										
NF & NF4 100-160 E	750	950	125	100	125	160	120	360	280	18	200	480
NF & NF4 100-160 D	750	950										
NF & NF4 100-160 C	750	1000										
NF & NF4 100-160 B	750	1070										
NF & NF4 100-160 A	765	1070										
NF & NF4 100-200 E	780	1075	125	100	125	160	120	360	280	18	200	480
NF & NF4 100-200 D	880	1075										
NF & NF4 100-200 C	880	1170										
NF & NF4 100-200 B	880	1235										
NF & NF4 100-200 A	880	1235										
NF & NF4 100-250 E	890	1190	125	100	140	160	120	400	315	18	225	505
NF & NF4 100-250 D	890	1255										
NF & NF4 100-250 C	980	1380										
NF & NF4 100-250 B	980	1380										
NF & NF4 100-250 A	980	1380										
NF & NF4 100-315 F	980	**	125	100	140	160	120	400	315	18	250	565
NF & NF4 100-315 E	980	**										
NF & NF4 100-315 D	980	**										
NF & NF4 100-315 C	1030	**										
NF & NF4 100-315 B	1030	**										
NF & NF4 100-315 A	1030	**										
NF & NF4 125-200 E	890	1090	150	125	140	160	120	400	315	18	250	565
NF & NF4 125-200 D	890	1180										
NF & NF4 125-200 C	890	1240										
NF & NF4 125-200 B	975	1370										
NF & NF4 125-200 A	975	1370										
NF & NF4 125-250 F	975	**	150	125	140	160	120	400	315	18	250	605
NF & NF4 125-250 E	975	**										
NF & NF4 125-250 D	975	**										
NF & NF4 125-250 C	975	**										
NF & NF4 125-250 B	1030	**										
NF & NF4 125-250 A	1030	**										

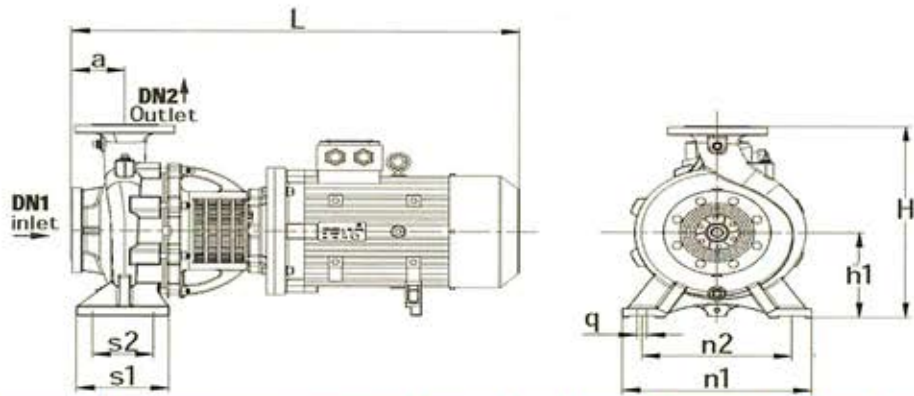

Type	L		DN1	DN2	a	s1	s2	n1	n2	q	h1	H
	1450 rpm	2900 rpm										
NF & NF4 125-315 F	985	**	150	125	140	160	120	400	315	18	280	635
NF & NF4 125-315 E	1045	**										
NF & NF4 125-315 D	1045	**										
NF & NF4 125-315 C	1110	**										
NF & NF4 125-315 B	1110	**										
NF & NF4 125-315 A	1110	**										
NF & NF4 150-200 F	920	**	200	150	160	200	150	550	450	23	280	680
NF & NF4 150-200 E	920	**										
NF & NF4 150-200 D	1000	**										
NF & NF4 150-200 C	1000	**										
NF & NF4 150-200 B	1000	**										
NF & NF4 150-200 A	1000	**										
NF & NF4 150-250 F	1000	**	200	150	160	200	150	500	400	23	280	680
NF & NF4 150-250 E	1000	**										
NF & NF4 150-250 D	1050	**										
NF & NF4 150-250 C	1050	**										
NF & NF4 150-250 B	1050	**										
NF & NF4 150-250 A	1110	**										
NF & NF4 150-315 F	1070	**	200	150	160	200	150	550	450	23	280	680
NF & NF4 150-315 E	1070	**										
NF & NF4 150-315 D	1130	**										
NF & NF4 150-315 C	1130	**										
NF & NF4 150-315 B	1130	**										
NF & NF4 150-315 A	1130	**										